

Jacksonville Tree Commission

TASK FORCE ON URBAN TREE PLANTING BEST PRACTICES

February 20, 2025 11:00am - 2:00pm

**Ed Ball Building, 10th Floor, Conference Room 5
and Zoom Webinar**

All agenda materials will be available at <https://www.jacksonville.gov/departments/public-works/tree-commission> by Thursday, February 13, 2025 under the meeting link (Task Force Urban Tree Planting Best Practices Meeting Notice* February 20, 2025 11:00am - 2:00pm)

Task Force Members:

Susan Fraser, Tree Commission Member, Chair
Nina Sickler Tree Commission Member, Vice-Chair
Curtis Hart, Tree Commission Member
William Burke, Tree Commission Member

Non-Member attendees:

Jeff Lucovsky, PDDS
Jonathan Johnston, Parks
Guy Parola, DIA
Nancy Powell, Scenic Jax
Lisa Grubba, Greenscape
Valerie Feinberg, Fuse Fellow, UFMP

Advisors:

Jonathan Colburn, Urban Forestry Manager
Justin Gearhart, City Arborist
Shannon MacGillis, Office of General Council

Staff:

Joe Rainey, Executive Assistant

AGENDA

Order of Agenda is Subject to Change

- 1. Call to Order – Chair**
- 2. Roll Call and Verification of Quorum – Chair** Submittal of Speaker’s cards
- 3. Public Comment: (up to 3 minutes, allotted at discretion of Chair)**
- 4. Submittal of Speaker’s Cards – Chair**
 - a.** A raised hand icon will be acknowledged by the Chair.
 - b.** For those attending in person, paper speakers’ cards will be available.

- 5. Approval of Minutes of January 27, 2025 Task Force Meeting**
 - a. Policy Position Discussion
 - i. Plant for longevity and ultimate size.
 - ii. Natural Solutions First, constraints' mitigation second.
 - iii. Preserve soil structure.

- 6. Existing Standards Review Presentations** (materials/summaries under meeting link)
 - a. ANSI A300 - Susan Fraser
 - b. JEA Underground Utilities – Joe Anderson
 - c. Minimum Planting Area Detail – Susan Fraser
 - d. Silva Cell Details – JTA Busway on Park Street
 - e. Vertical Constraints – Jonathan Colburn
 - f. Existing Tree Fund Projects' Irrigation Approach – Jonathan Colburn

- 7. Downtown Investment Authority**
 - a. Examples of Utility Conflicts Downtown – Guy Parola
 - b. Design Guidebook - Guy Parola

- 8. The Good, Bad and Ugly**

- 9. Development of Constrained Planting Environment Standards**
 - a. Overview “Bringing Order to the Technical Dysfunction within the Urban Forest”, Journal of Arboriculture Volume 18, issue 2, March 1992
 - b. Application of Approach and Matrix to Jacksonville
 - i. Matrix
 - ii. Mitigation by Degree of Urbanization
 - iii. Outline of Needed Specifications and Details
 - iv. Application Requirements Level 2 and 3 Checklists

- 10. Expand Approved Tree Planting List to Include:**
 - i. Planting Zone
 - ii. Mature Height and Spread
 - iii. Root Characteristics (invasive?)
 - iv. Suitability as a street tree adjacent to pedestrians
 - v. Suitability as street tree without pedestrian adjacency
 - vi. Maintenance Score
 - vii. Wind Resistance
 - viii. Water requirements minimum and Optimum
 - ix. soil volume required
 - x. Lifespan
 - xi. Crown shape

13. Meeting Dates for March - May 2025

March 20th 11am -2pm

April 17th 11am -2pm

May 14th 11am -2pm

ADJOURNMENT

Summary and Excerpts from American National Standards Institute A300 Standards, December 2023 Tree Care Standards for trees, shrubs, palms and other woody landscape plants

ANSI A300 is the tree care industry standard of care in the USA. It was developed by Tree Care Industry Association and is maintained by consensus of various industry stakeholders through periodically reviewing and updating the guidelines. The standard is divided into ten parts, of which Part 5 – Management of Trees on Construction Sites is the most relevant to the work of the Task Force under Task 1.

Other standards in A300 are summarized below for use by the Task Force on other Tasks under its Charge Memo.

Section 4.1 Inspections

4.1.2 *Location of Utilities*

4.2.1 *Visual Inspection to identify conditions that would affect the scope of work*

Section 4.4 Work Specifications (= Maintenance Plan)

Develop before proposing or commencing any tree care operation.

Section 4.5 Work Practices

Describes how tree care shall be performed; identifies testing, licensing and training requirements

Section 4.7 Monitoring and Maintenance

4.7.1 *Identifies monitoring intervals*

4.7.2 *Maintenance requirements are made to the Client.*

4.7.3 *Provides that scheduling maintenance shall be the responsibility of the Client.*

Part 5. Management of Trees on Construction Sites

Section 5.3 Pruning Objectives

- Manage Risk
- Manage Health
- Provide Clearance
- Manage Size or Shape
- Improve Aesthetics
- Manage Wildlife habitat

Section 6. **Soil Assessment**

Provides that samples shall be representative of the site and shall address:

- Surface Drainage
- Soil Profile
- Soil Drainage (infiltration and percolation)
- Depth to water table
- Soil Texture

- Bulk Density (weight of dried soil per unit of volume – a measure of soil compaction)
- Salts
- Nutrients
- Soil pH
- Organic matter content

Section 6.4 Soil Management Objectives

6.4.1 *Assess to Improve Tree Health or Avoid Future Problems (7 of 9 listed /relevant):*

- Manage soil organic matter content
- Mitigate soil compaction
- Correct nutrient deficiencies
- Moderate soil temps
- Improve soil structure
- Manage soil moisture content
- Manage soil biology

6.7.2 *Soil Amendment*

6.7.2.1 If soil organic matter is outside the desirable range, treatment recommended based on soil analysis results.

6.7.3 *Soil Tilling*

6.7.3.3 Pneumatic tilling should be preferred method to mitigate compacted soil within the root zone of plants.

Section 6.8 Fertilization Practices

Section 6.9 Drainage Practices

Treatment to mitigate may include:

- Reduce soil compaction
- Application of organic mulch
- Deep cultivation of impervious layers
- Grade changes
- Swales, ditches, drainpipes

6.9.3 When it is not practical to mitigate, species tolerant of wet soils should be selected,

6.9.4 When improvement is not practical, planting on soil mounds or berms should be preferred.

6.9.5 Install drainage system to prevent water accumulating behind retaining walls.

6.9.6 Require sufficient slope to achieve drainage desired.

6.9.7 Mitigation of Impenetrable Soil Layers (how to).

6.9.9 Mitigation/ Adjustment of Subsurface Drainage (specifications).

Section 6.10 Monitoring and Maintenance

- Establishes inspections schedule
- Establishes monitoring intervals within the warranty period
- Establishes monitoring intervals post- warranty

C6-Annex A. Soil Management Specifications

Guidance/ outline / how to draft work specifications.

C6- Annex B. Site Soil Sampling Guidelines

B-6 Sampling Guidelines Specific to pH

Section 9. Management During Site Development & Construction

9.2.1 Objectives (pertinent)

- Minimize conflicts between trees and new infrastructure
- Minimize damage to trees and soil

Section 9.4 Planning Phase

9.4.1 During pre-planning, tree protection standards are established.

Section 10. Planting – Transplant Standards

10.4.3 Written Specs for planting should include:

Installation Requirements

- Planting hole dimensions (shape, width/dia., depth)
- Backfill material
- Initial watering required
- Mulch type, depth and area
- Support System

10.4.4.1 Plant Acceptance Criteria (excerpt)

- Root collar visibility
- Rootball moisture requirement
- Presence of existing or potential stem girdling roots
- Other issues impacting survival potential

10.6.3 Post Planting Maintenance

- Soil Moisture Management
- Protection from mechanical injury, animals, competing vegetation, other.
- Integrated Pest Management
- Pruning
- Maintenance / removal of tree
- Support systems and trunk protection

ANSI A300 includes sample specifications.

Filing an Application for Planting in an Urban Environment

Apply Organizing Characteristics based on the condition of the planting environment (area within the root zone of all planted trees) at time of planting. Multiple conclusions may apply based on location within a project boundary.

Soil Disturbance

Grading has occurred

Compaction has occurred

Potential Mitigation Strategies

- a. Limit construction area: establish limits of grading outside of all root zones of planted and retained trees.
- b. Limit all access (including laydown areas, delivery, storage, debris collection, etc.) to area outside of all root zones of planted and retained trees.

Impervious Area

Less than 15%

15% to 50%

50% to 70%

70% to 90%

Greater than 90%

Potential Mitigation Strategies

- a. Use of pervious pavers with limited compacted subbase.

Apply Mitigation Strategies based on Urban Score(s) – See Matrix. Multiple Urban Scores may apply; strategies may differ within a project boundary.

Soil Quantity Goal:

Provide enough soil of suitable quality to support the tree mass proposed.

Required soil volume (see Soil Volume Strategies for details):

Small Tree:	300 cubic feet**	Min vertical volume: 100 sf *
Medium Tree:	1,200 cubic feet**	Min. vertical volume: 400 sf *
Large Tree:	1,800 cubic feet**	Min vertical volume: 600 sf*

**Minimum depth of 3 feet.

*Minimum distance to trunk at planting is 5 feet

1. Identify compliance with minimum planting areas above based on tree size.
2. Demonstrate compliance with application of mitigation : S1, S2, S3, S4 or S5

Drainage Goal:

Drainage adequate to obtain root growth in the soil.

1. *Demonstrate compliance with application of mitigation: D1.1, D1.2, D1.3, D2, D3.1, or D 3.2.*
2. *Provide detail of final grade and slope from trunk for all tree planting areas with impervious area of greater than 50% of the minimum surface area. **What is desired standard to insure adequate access to water ?***

Aeration Goal:

Provide sufficient air to the root zone to address effectiveness of the available soil.

1. *Demonstrate compliance with application of mitigation: A1, A2, A3.1, A3.2, or A4*

Contributing Factors

Provide Additional Assessment as indicated.

Soil Texture- Very sandy, silty or clayey soils require recommendations of a soil scientist. Require ID of soils present to determine need for report/ consultation.

1. *Identify existing soils on site from USDA Websoilsurvey (WSS). Identify soil type for each area of urban planting.*
2. *If imported soil/topsoil is proposed, provide soil analysis for soil within each area of urban planting.*
3. *If soils have been disturbed by prior development or other activity, provide Phase 1 Environmental Report of history of the site and, as indicated, soil samples for urban planting areas may be required.*

Submit soil report prepared by a licensed Soil Scientist to identify specific recommendations.

Soil Profile- Unusual soil profiles require special details (hardpan, shallow rock, underground structures).

1. *Identify location of underground utilities within all planting areas (depth, horizontal location and type). Standard location can be assumed if located within a City right of way unless non-standard location is identified by utility provider.*
2. *If underground utilities are located within an urban planting area, identify the volume of the planting area encumbered by utilities. Compensate for lost volume in area provided for each urban tree planting area when utilities encumber greater than 10% of the required soil volume.*

Site History- Age of buildings and site work affects the likelihood of disrupted soil structure. Prior to 1940, site work resulted in less impact to the soil based on the way land was developed. Sites that have had several changes in configuration (grades or structures) may require more site modifications than indicated.

1. *Assume compacted soils when planting area is located within any development site or right of way (only parks to be excluded). Assumption can be rebutted with bulk density testing within proposed planting areas.*

Maintenance – Recommendations all assume some minimal maintenance is available on a long term basis. This includes regular pruning, watering during initial grow-in periods, and some ongoing insect and disease control. Less maintenance will require more site modification to grow similarly sized trees. More, particularly irrigation and fertilizer, will allow for slightly less site modification.

1. *Provide a post planting, warranty period maintenance plan. Projects constructed under City Tree Mitigation Contract are assumed to meet minimum maintenance requirements for the warranty period.*
2. *Provide an enforceable maintenance agreement for post warranty maintenance. City maintained projects shall be subject to adopted standards for post warranty maintenance that are in compliance with terms of a non-city maintenance agreement.*

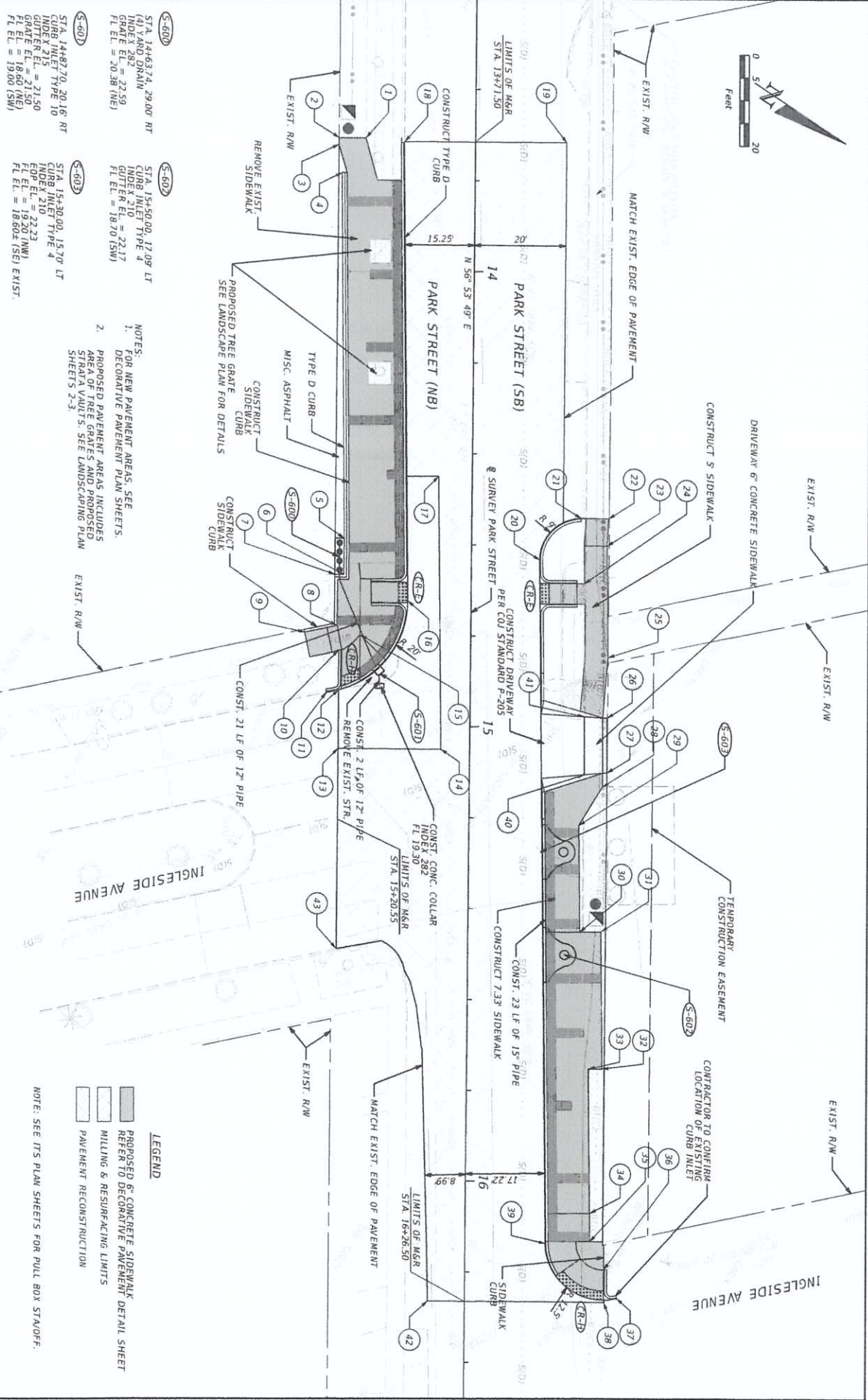
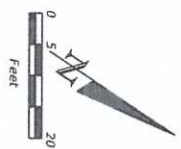

- (S-600) STA. 14+63.74, 29.00' RT
C&G AND DRAIN
INDEX 215
GATE EL. = 22.59
FL EL. = 20.38 (NE)
- (S-600) STA. 15+50.00, 12.09' LT
CURB INLET TYPE 4
INDEX 210
GUTTER EL. = 22.17
FL EL. = 18.70 (SW)
- (S-603) STA. 15+30.00, 15.70' LT
CURB INLET TYPE 4
INDEX 210
EOP EL. = 22.23
GATE EL. = 21.50
FL EL. = 18.60 (NE)
FL EL. = 19.00 (SW)

- NOTES:
1. FOR NEW PAVEMENT AREAS, SEE DECORATIVE PAVEMENT PLAN SHEETS.
 2. PROPOSED PAVEMENT AREAS INCLUDES AREA OF TREE GRATES AND PROPOSED STAIRA VAULTS. SEE LANDSCAPING PLAN SHEETS 2-3.

- LEGEND
- PROPOSED 6" CONCRETE SIDEWALK DETAIL SHEET
 - REFER TO DECORATIVE PAVEMENT LIMITS
 - MILLING & RESURFACING LIMITS
 - PAVEMENT RECONSTRUCTION

NOTE: SEE ITS PLAN SHEETS FOR PULL BOX STANDOFF.

DATE	REVISIONS		
		 HNTB ENGINEER OF RECORD: FERRIS SHAW, P.E. FLORIDA REGISTRATION NO. 50096	 Flyer ENGINEER OF RECORD: FERRIS SHAW, P.E. FLORIDA REGISTRATION NO. 50096
		JACKSONVILLE TRANSPORTATION AUTHORITY SW BRT CORRIDOR	PARK ST. / WOLFE ST. PLAN SHEET (22)
		SHEET NO. 21	

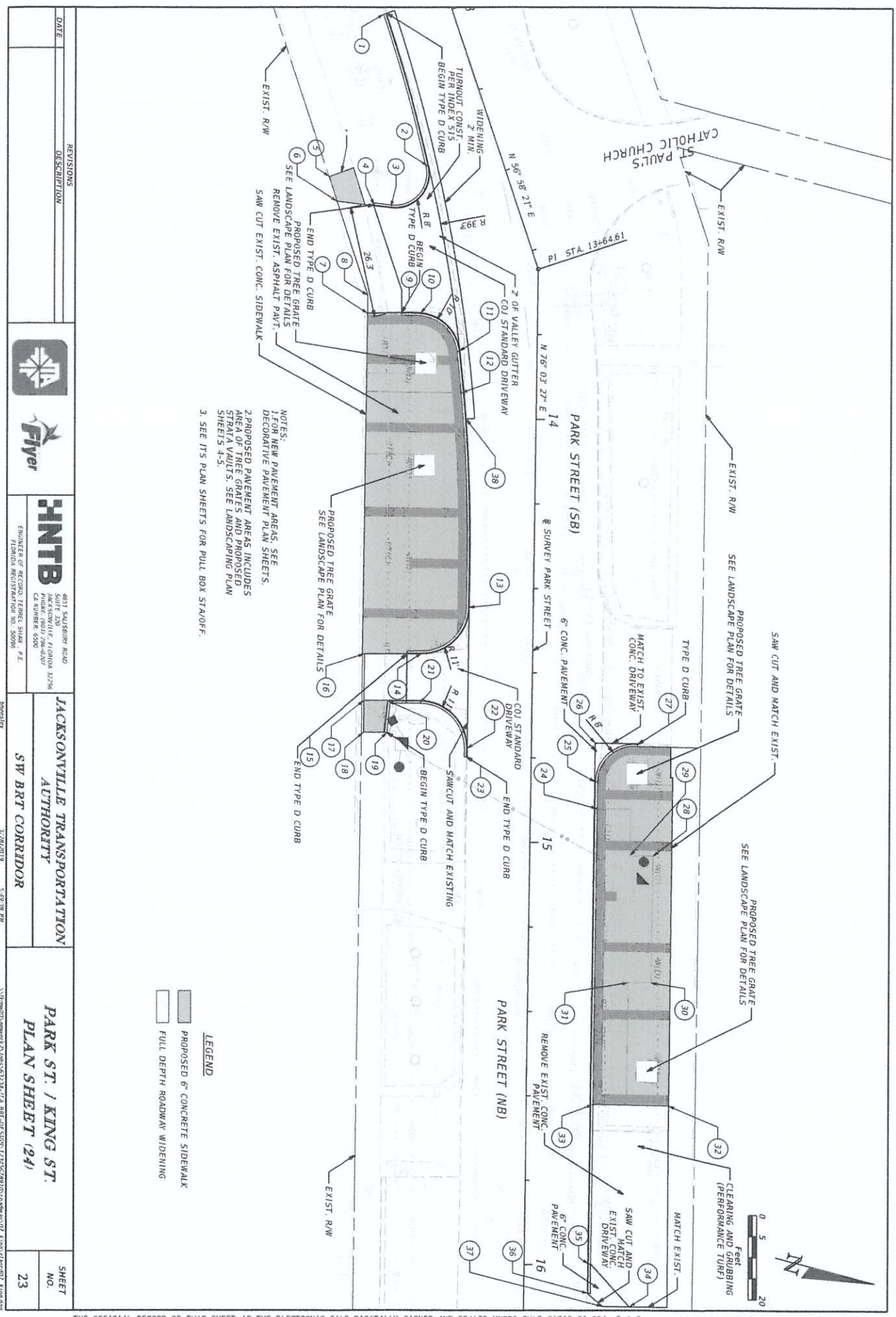

NOTES:
 1. FOR NEW PAVEMENT AREAS, SEE DECORATIVE PAVEMENT PLAN SHEETS.
 2. PROPOSED PAVEMENT AREAS INCLUDES AREA OF TREE GRATES AND PROPOSED STRATA WALLS. SEE LANDSCAPING PLAN SHEETS 4-5.
 3. SEE ITS PLAN SHEETS FOR PULL BOX STAFFS.

LEGEND
 [Shaded Box] PROPOSED 6" CONCRETE SIDEWALK
 [White Box] FULL DEPTH ROADWAY WIDENING

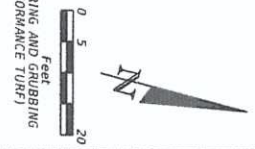

DATE	REVISIONS DESCRIPTION	SHEET NO.
		23

 HNTB ENGINEER OF RECORD, FURNISHING PLAN SHEETS JACKSONVILLE, FLORIDA 32208 4501 SAULSBURY ROAD SUITE 200 JACKSONVILLE, FLORIDA 32208 CA NUMBER 6500	JACKSONVILLE TRANSPORTATION AUTHORITY SW BRT CORRIDOR	PARK ST. / KING ST. PLAN SHEET (24)
---	---	--

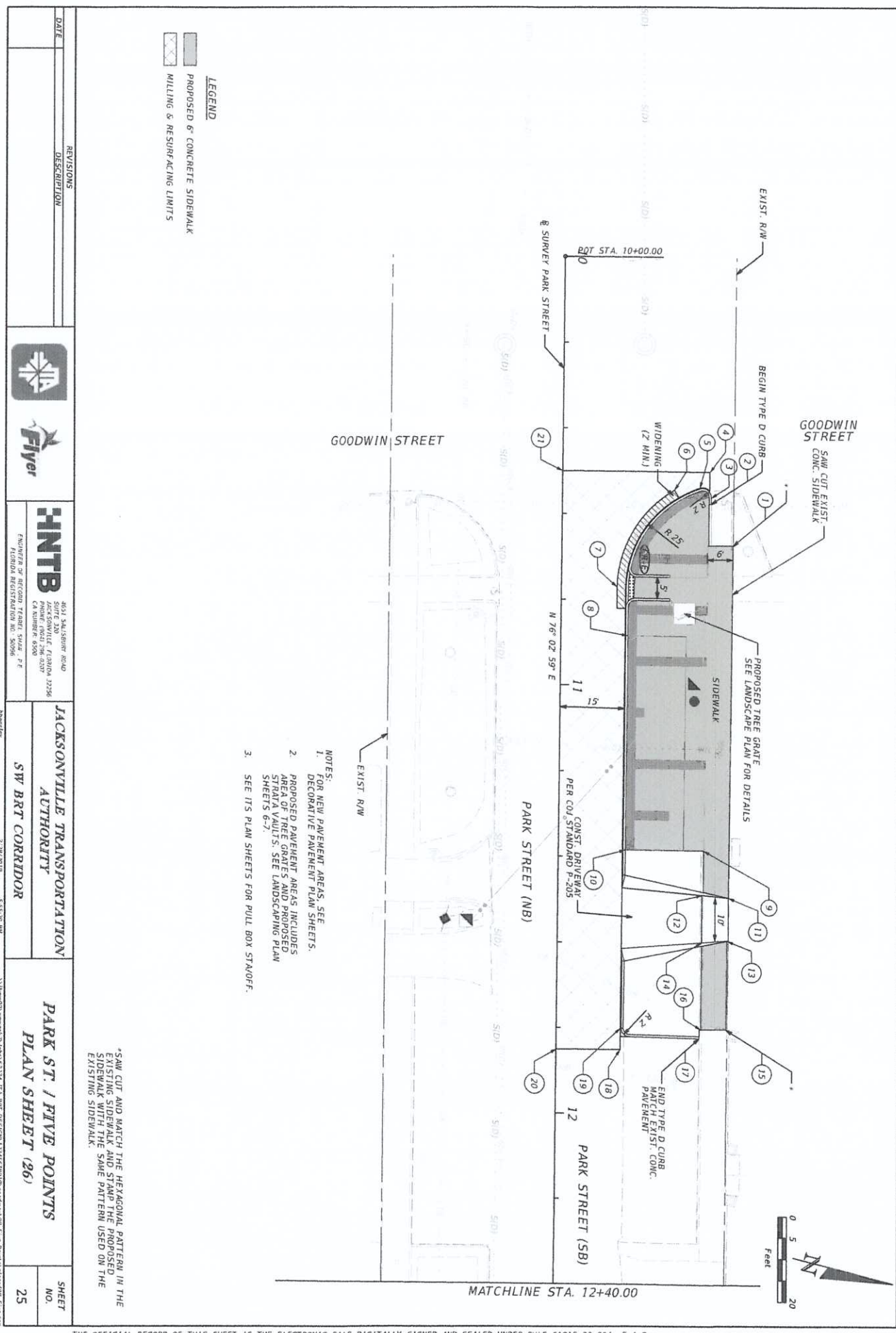

- LEGEND**
- PROPOSED 6" CONCRETE SIDEWALK
 - MILLING & RESURFACING LIMITS

- NOTES:**
1. FOR NEW PAVEMENT AREAS, SEE DECORATIVE PAVEMENT PLAN SHEETS.
 2. PROPOSED PAVEMENT AREAS INCLUDES EXISTING AREAS AND PROPOSED STRATA VAULTS. SEE LANDSCAPING PLAN SHEETS 6-7.
 3. SEE ITS PLAN SHEETS FOR PULL BOX STA/OFF.

*SAW CUT AND MATCH THE HEXAGONAL PATTERN IN THE EXISTING SIDEWALK AND STAMP THE PROPOSED SIDEWALK WITH THE SAME PATTERN USED ON THE EXISTING SIDEWALK.

DATE	REVISIONS	DESCRIPTION	SHEET NO.
			25

 HNTB <small>ENGINEER OF RECORD, TRAFFIC ENGINEER</small> <small>FLORIDA REGISTRATION NO. 50966</small>	 Flyer <small>CONSULTING ENGINEER</small>	JACKSONVILLE TRANSPORTATION AUTHORITY SW BRT CORRIDOR
---	--	--

JACKSONVILLE TRANSPORTATION AUTHORITY <small>401 N. WASHINGTON ROAD SUITE 201 JACKSONVILLE, FLORIDA 32206 PHONE: 904.241.4000 FAX: 904.241.4001</small>	PARK ST. / FIVE POINTS PLAN SHEET (26)
---	---

26" V. CONDUCTOR

S/D1 S/D2 S/D3 S/D4 S/D5 S/D6 S/D7 S/D8 S/D9 S/D10 S/D11 S/D12 S/D13 S/D14 S/D15 S/D16 S/D17 S/D18 S/D19 S/D20 S/D21 S/D22 S/D23 S/D24 S/D25 S/D26 S/D27 S/D28 S/D29 S/D30 S/D31 S/D32 S/D33 S/D34 S/D35 S/D36 S/D37 S/D38 S/D39 S/D40 S/D41 S/D42 S/D43 S/D44 S/D45 S/D46 S/D47 S/D48 S/D49 S/D50 S/D51 S/D52 S/D53 S/D54 S/D55 S/D56 S/D57 S/D58 S/D59 S/D60 S/D61 S/D62 S/D63 S/D64 S/D65 S/D66 S/D67 S/D68 S/D69 S/D70 S/D71 S/D72 S/D73 S/D74 S/D75 S/D76 S/D77 S/D78 S/D79 S/D80 S/D81 S/D82 S/D83 S/D84 S/D85 S/D86 S/D87 S/D88 S/D89 S/D90 S/D91 S/D92 S/D93 S/D94 S/D95 S/D96 S/D97 S/D98 S/D99 S/D100

8" VC GRAY SEW

14 PARK STREET (SB) @ SURVEY PARK STREET

12" PVC WM

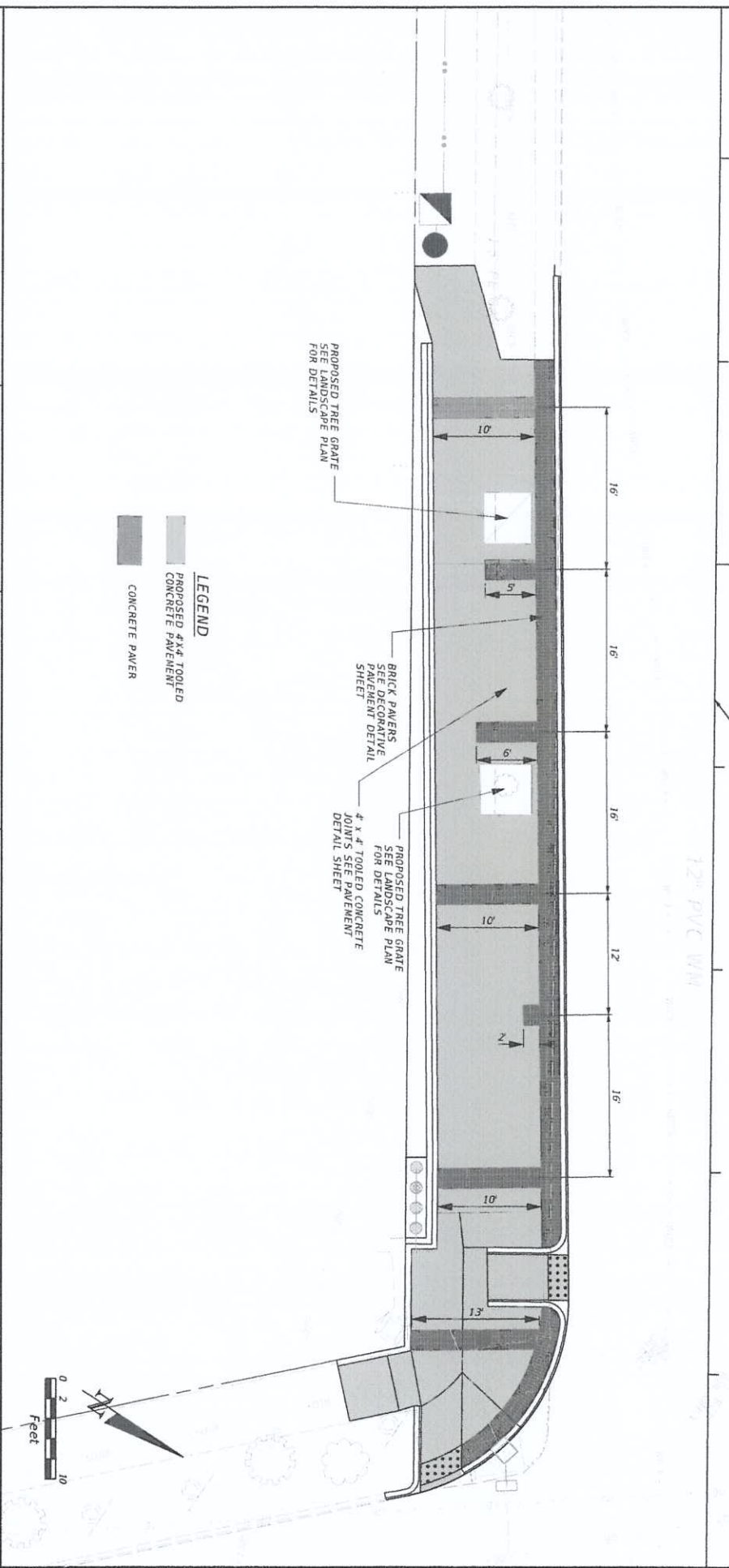

LEGEND

- PROPOSED 4'x4' TOOLED CONCRETE PAVEMENT
- CONCRETE PAVER

REVISIONS		DATE	
NO.	DESCRIPTION		

 HNTB <small>ARCHITECT OR RECORD CONSULTANT D. KELLER</small>	<small>7077 BARNES/AL ROAD</small> <small>SUITE 600 FT/LA</small> <small>JACKSONVILLE, FLORIDA 32216</small> <small>PHONE: (904) 296-0200</small> <small>CA NUMBER: 6008</small>	JACKSONVILLE TRANSPORTATION AUTHORITY SW BRT CORRIDOR	PARK ST. / WOLFE ST. DECORATIVE PAVEMENT PLAN SHEET (1)	SHEET NO. 30
	<small>PROJECT</small> <small>3/28/2019</small>			

\\nas001\project\2\JABS\032324\11_BRT-05\BRT\124548\10\plan\top\plan\008_30\plan\19

DATE OF SURVEY: 05/20/17 TO 07/20/17
 SURVEY MADE BY: CSI GEO. INC.
 SUBMITTED BY: BRUCE KHOSROZADEH, P.E.

JACKSONVILLE TRANSPORTATION AUTHORITY
 ROADWAY SOIL SURVEY
 REPORT OF TESTS

PROJECT NAME: BUS RAPID TRANSIT - SOUTHWEST CORRIDOR

SURVEY BEGINS STA.: 13+09 SURVEY ENDS STA.: 13+71 REFERENCE: SURVEY ORANGE PARK MALL
 SURVEY BEGINS STA.: 11+23 SURVEY ENDS STA.: 15+73 REFERENCE: SURVEY PARK STREET
 SURVEY BEGINS STA.: 103+00 SURVEY ENDS STA.: 301+47 REFERENCE: SURVEY SR 21

STRAIUM NO.	NO. OF TESTS	ORGANIC CONTENT	% ORGANIC	NO. OF TESTS	MOISTURE CONTENT	NO. OF TESTS	NO. OF TESTS	SIEVE ANALYSIS RESULTS					ATTENBERG LIMITS (%)	DESCRIPTION	NO. OF TESTS	CORROSION TEST RESULTS				ENVIRONMENTAL CLASSIFICATION		
								10 MESH	40 MESH	60 MESH	100 MESH	200 MESH				LIQUID LIMIT	PLASTIC INDEX	PLASTIC GROUP	RESISTIVITY ohm-cm		CHLORIDE ppm	SULFATES ppm
1	1	2	10	5-24	10	99-100	86-89	48-51	16-26	4-10	-	-	A-3	GRAY AND BROWN FINE SAND	11	3,878-31,280	240-420	U-51	7.8-8.9	EXTREMELY AGGRESSIVE	EXTREMELY AGGRESSIVE	
2	-	-	9	9-25	9	99	86	59	31	12-29	-	-	A-2-4	GRAY AND BROWN SILTY FINE SAND	3	5,450-49,970	180-300	3-12	7.9-9.0	EXTREMELY AGGRESSIVE	EXTREMELY AGGRESSIVE	
3	-	-	8	19-26	8	-	-	-	-	28-49	8	29-40	11-23	A-2-6/A-6	GRAY AND BROWN CLAYEY FINE SAND (LL<50)	2	10,360-10,960	240-360	21-39	5.3-6.3	EXTREMELY AGGRESSIVE	EXTREMELY AGGRESSIVE
4	-	-	2	31-33	2	-	-	-	-	68-69	2	55-65	30-45	A-7-6	GRAY AND BROWN SANDY CLAY (LL>50)	-	-	-	-	-	-	-
5	-	-	-	-	-	-	-	-	-	-	-	-	-	ASPHALT	-	-	-	-	-	-	-	-
6	-	-	-	-	-	-	-	-	-	-	-	-	-	LIMEROCK	-	-	-	-	-	-	-	-

EMBANKMENT AND SUBGRADE MATERIAL
 STRATA BOUNDARIES ARE APPROXIMATE. MAKE FINAL CHECK AFTER GRADING.
 X - ESTIMATED SEASONAL HIGH GROUNDWATER LEVEL
 W - WATER TABLE ENCOUNTERED
 A.T. - AUGER TERMINATION
 B.T. - BORING TERMINATION
 G.N.E. - GROUNDWATER NOT ENCOUNTERED
 U - COMPOUND TESTED FOR BUT NOT DETECTED

- NOTE:
- THIS SOIL SURVEY APPLIES TO ROADWAY.
 - STRATA BOUNDARIES ARE APPROXIMATE AND REPRESENT SOIL STRATA AT EACH TEST HOLE LOCATION. ANY STRATUM CONNECTING LINES SHOWN ARE FOR DESIGN PURPOSES ONLY AND DO NOT INDICATE ACTUAL STRATUM LIMITS. SUBSURFACE VARIANCE BETWEEN BORINGS MAY OCCUR AND SHOULD BE ANTICIPATED.
 - THE MATERIAL FROM STRATUM NO. 1 IS SELECT MATERIAL AND APPEARS SATISFACTORY FOR USE WHEN UTILIZED IN ACCORDANCE WITH STANDARD PLANS INDEX 120-001.
 - THE MATERIAL FROM STRATUM NO. 2 IS SELECT MATERIAL AND APPEARS SATISFACTORY FOR USE WHEN UTILIZED IN ACCORDANCE WITH STANDARD PLANS INDEX 120-001. HOWEVER, THIS MATERIAL MAY RETAIN EXCESS MOISTURE AND MAY BE DIFFICULT TO DRY AND COMPACT. IT SHOULD BE PLACED ABOVE THE EXISTING WATER TABLE AT THE TIME OF CONSTRUCTION.
 - THE MATERIAL FROM STRATUM NO. 3 SHALL BE REGARDED AS PLASTIC MATERIAL.
 - THE MATERIAL FROM STRATUM NO. 4 SHALL BE REGARDED AS HIGHLY PLASTIC MATERIAL.
 - REMOVAL OF PLASTIC AND HIGHLY PLASTIC MATERIALS OCCURRING WITHIN THE ROADWAY SHALL BE COMPLETED AND ACCORDANCE WITH STANDARD PLANS INDEX 120-001 SHALL BE IN ACCORDANCE WITH STANDARD PLANS INDEX 120-001.

DATE	REVISIONS	DESCRIPTION	SHEET NO.
			41



CSI Geo. Inc.
 ENGINEER OF RECORD, BRUCE KHOSROZADEH, P.E.
 (FLORIDA LICENSE NO. 12003)

JACKSONVILLE TRANSPORTATION AUTHORITY

SW BRT CORRIDOR

SOIL SURVEY SHEET

32nd ST. ADAMS BLVD. ROAD 9
 SUITE 200
 JACKSONVILLE, FLORIDA 32246
 CA NUMBER: 98110

5/18/2019 6:49:39 PM \\vsm009\p\0173\000\42324-11A_BRT-CORRIDOR\123264\8910\5981CH\0556E011293

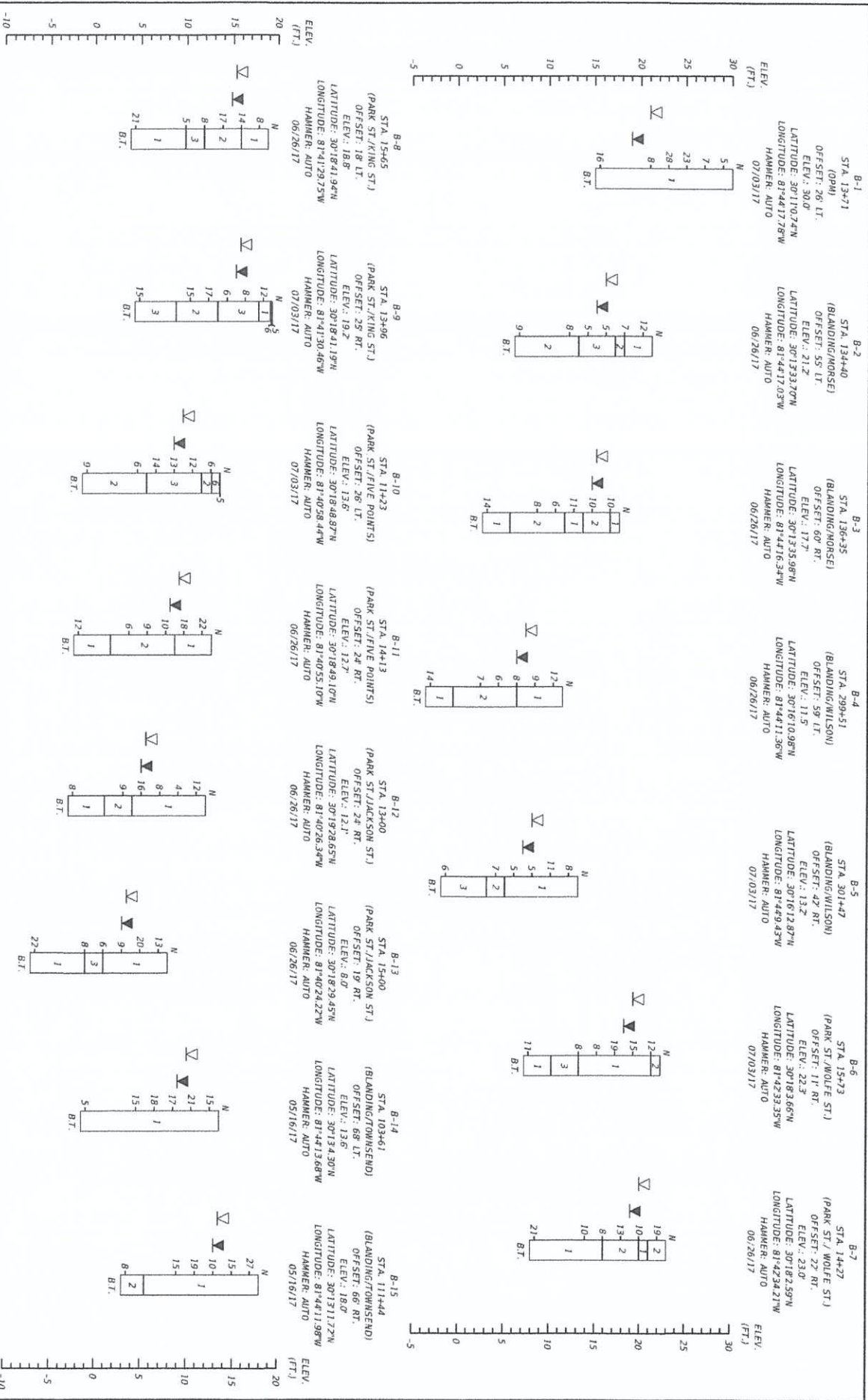

REVISIONS

DATE	DESCRIPTION

CSiGeo
 2305 SW JONES BLVD. SUITE 500
 SUITE 500, AUSTIN, TEXAS 78746
 PHONE: (512) 441-2800
 CA NUMBER: 28170

JACKSONVILLE TRANSPORTATION AUTHORITY

SW BRT CORRIDOR

GENERAL SUBSURFACE PROFILES

DATE: 12/21/2018 10:19:05 AM SHEET NO. 12

TREE REMOVAL TABULATION			
TYPE	DBH	REPLACEMENT REQUIRED	REPLACEMENT PROPOSED
LIVE OAK	13"	13"	10"
CREPE MYRTLE	24"	6"	0"

26KV OE CONDUCTOR

LIMITS OF CLEAR SIGHT

PARK STREET (SB)

STA 14+61 / LI 19' LT 1

14

SURVEY PARK STREET

EXISTING CREPE MYRTLE TO REMAIN

3 CREPE MYRTLES TO BE REMOVED

53.3'

PROPOSED STATION SEE STATION PLAN SHEET

1.5' PE

EXISTING SIDEWALK

LIVE OAK 8" TO BE REMOVED

CONTROLLER BOX

LIVE OAK 5" TO BE REMOVED





LIMITS OF CLEAR SIGHT

4' CLEAR FOR UTILITY STRIP

8.0'

EXIST. R/W

LEGEND

-  PROPOSED LIVE OAK
-  PROPOSED CREPE MYRTLE
-  PROPOSED STRATUM/MULTI-SEE LANDSCAPE DETAIL SHEETS
-  SIGHT LINE

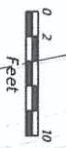

REVISIONS

DATE	DESCRIPTION



HNTB
4651 SALTIBURN ROAD
SUITE 200
JACKSONVILLE, FLORIDA 32256
ARCHITECT ON RECORD: CHRISTOPHER D. KEELER
R.L.A. NO. 000137

JACKSONVILLE TRANSPORTATION AUTHORITY
SW BRT CORRIDOR

PARK ST. / WOLFE ST.
LANDSCAPE PLAN SHEET (2)

SHEET NO. 94

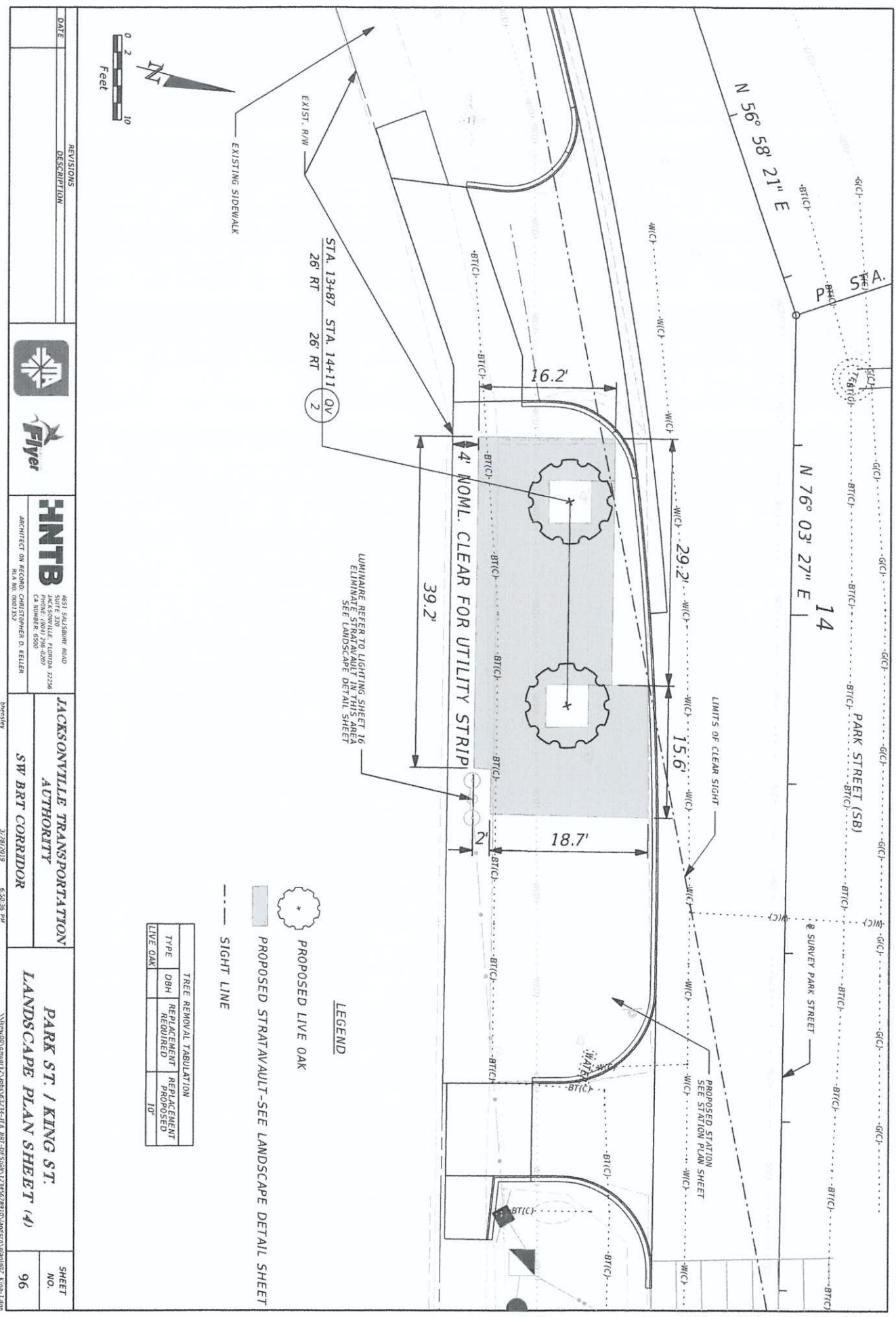

4511 SULLYBURN ROAD
SUITE 201
JACKSONVILLE, FLORIDA 32206
C.A. NUMBER: 6500
FLA. NO. 0001137

HNTB

ARCHITECT ON RECORD: CHRISTOPHER D. REIDER

JACKSONVILLE TRANSPORTATION AUTHORITY

SW BRT CORRIDOR

PARK ST. / KING ST.
LANDSCAPE PLAN SHEET (4)

96

DATE: _____

REVISIONS

DESCRIPTION

0 2 10 Feet

EXISTING SIDEWALK

EXIST. R/W

STA. 13+87 STA. 14+11

26' RT 26' RT

OV 2

16.2'

4' NOML. CLEAR FOR UTILITY STRIP

39.2'

LUMINAIRE REFER TO LIGHTING SHEET 16
ELIMINATE STRATVAULT IN THIS AREA
SEE LANDSCAPE DETAIL SHEET

18.7'

2'

29.2'

15.6'

LIMITS OF CLEAR SIGHT

PROPOSED STRATVAULT-SEE LANDSCAPE DETAIL SHEET

PROPOSED STATION SHEET
SEE STATION PLAN SHEET

N 56° 58' 21" E

N 76° 03' 27" E

14

PARK STREET (SB)

SURVEY PARK STREET

LEGEND

- PROPOSED LIVE OAK
- PROPOSED STRATVAULT-SEE LANDSCAPE DETAIL SHEET
- SIGHT LINE

TREE REMOVAL TABULATION			
TYPE	DBH	REPLACEMENT REQUIRED	REPLACEMENT PROPOSED
LIVE OAK			10'

TREE REMOVAL/TABLICATION			
TYPE	DBH	REPLACEMENT REQUIRED	REPLACEMENT PROPOSED
LIVE OAK	59"	59"	20"

- LEGEND**
- PROPOSED CREPE MYRTLE
 - PROPOSED LIVE OAK
 - PROPOSED STRATAVAULT-SEE LANDSCAPE DETAIL SHEET
 - SIGHT LINE

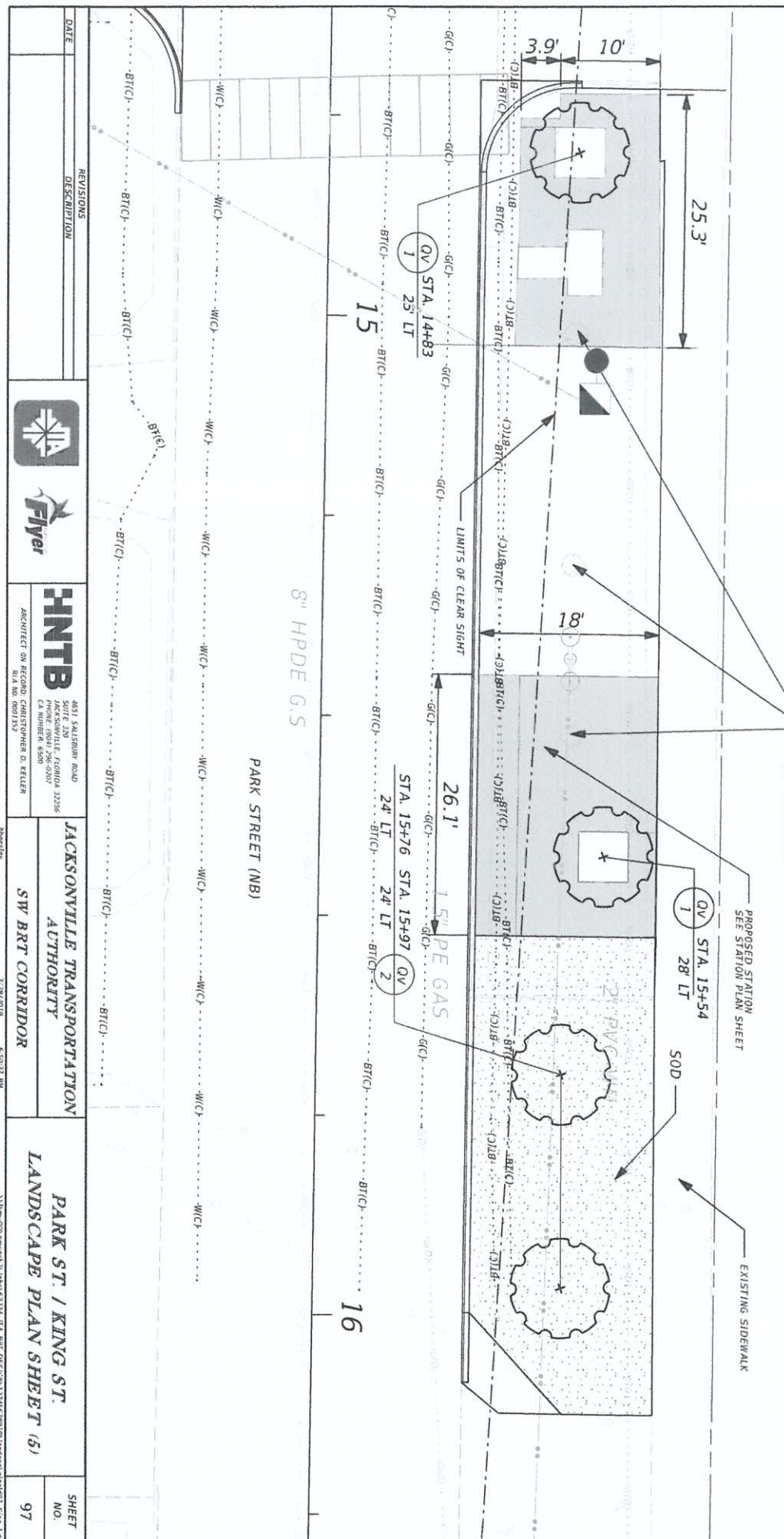
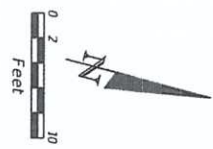

DATE	REVISIONS	DESCRIPTION	SHEET NO.
			97



HNTB
 ARCHITECT ON RECORD CONSULTANTS D. KELLER
 4621 WASHINGTON ROAD
 SUITE 230
 JACKSONVILLE, FLORIDA 32236
 CA NUMBER: 6500
 FLA NO. 000137

JACKSONVILLE TRANSPORTATION AUTHORITY
 SW BRT CORRIDOR

PARK ST. / KING ST. LANDSCAPE PLAN SHEET (5)

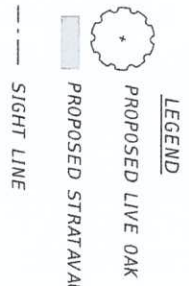
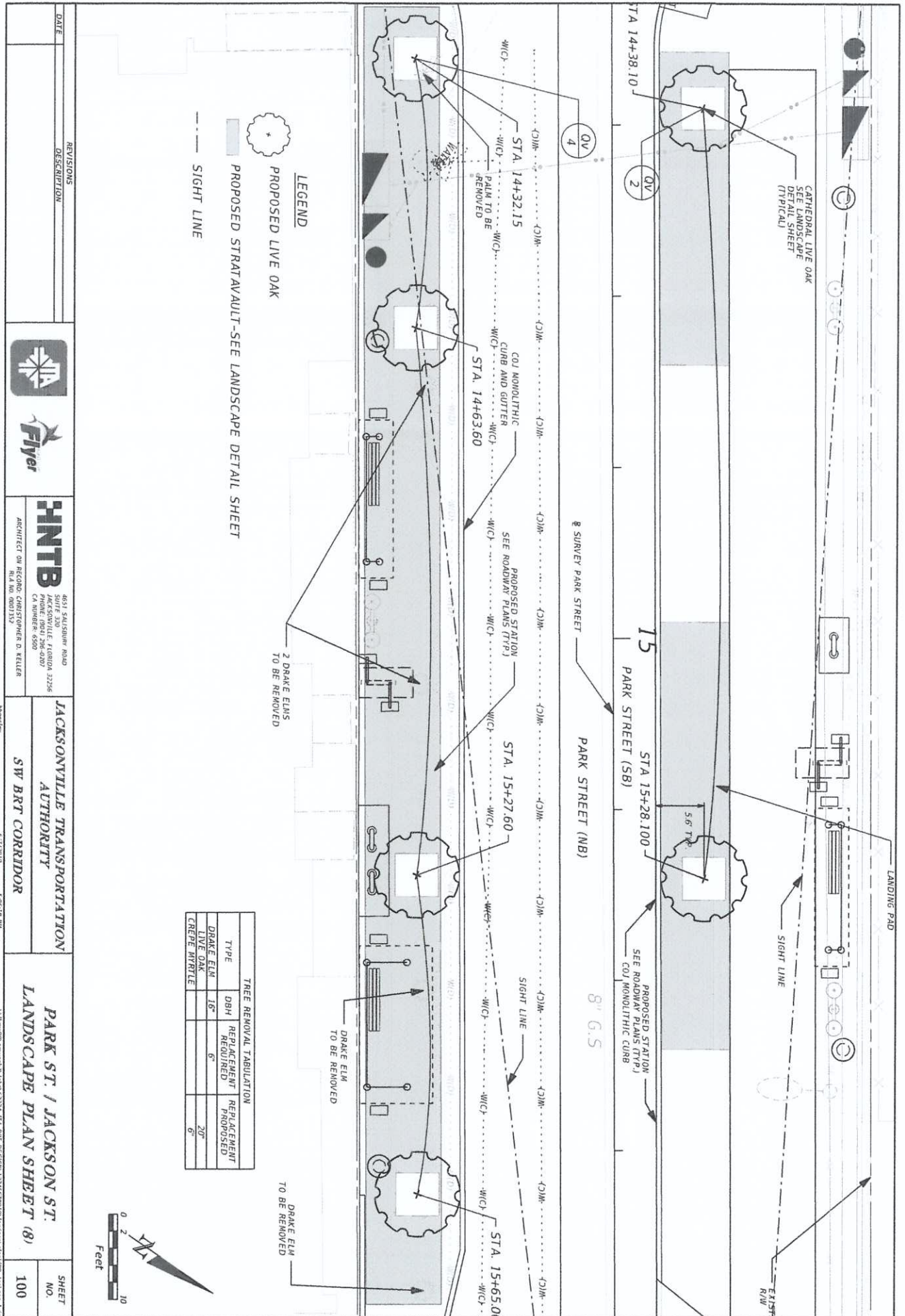

TREE REMOVAL TABULATION

TYPE	DBH	REPLACEMENT REQUIRED	REPLACEMENT PROPOSED
DRAKE ELM	16"	6"	20"
LIVE OAK		6"	6"
CREPE MYRTLE			6"

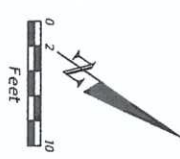

REVISIONS		DATE	

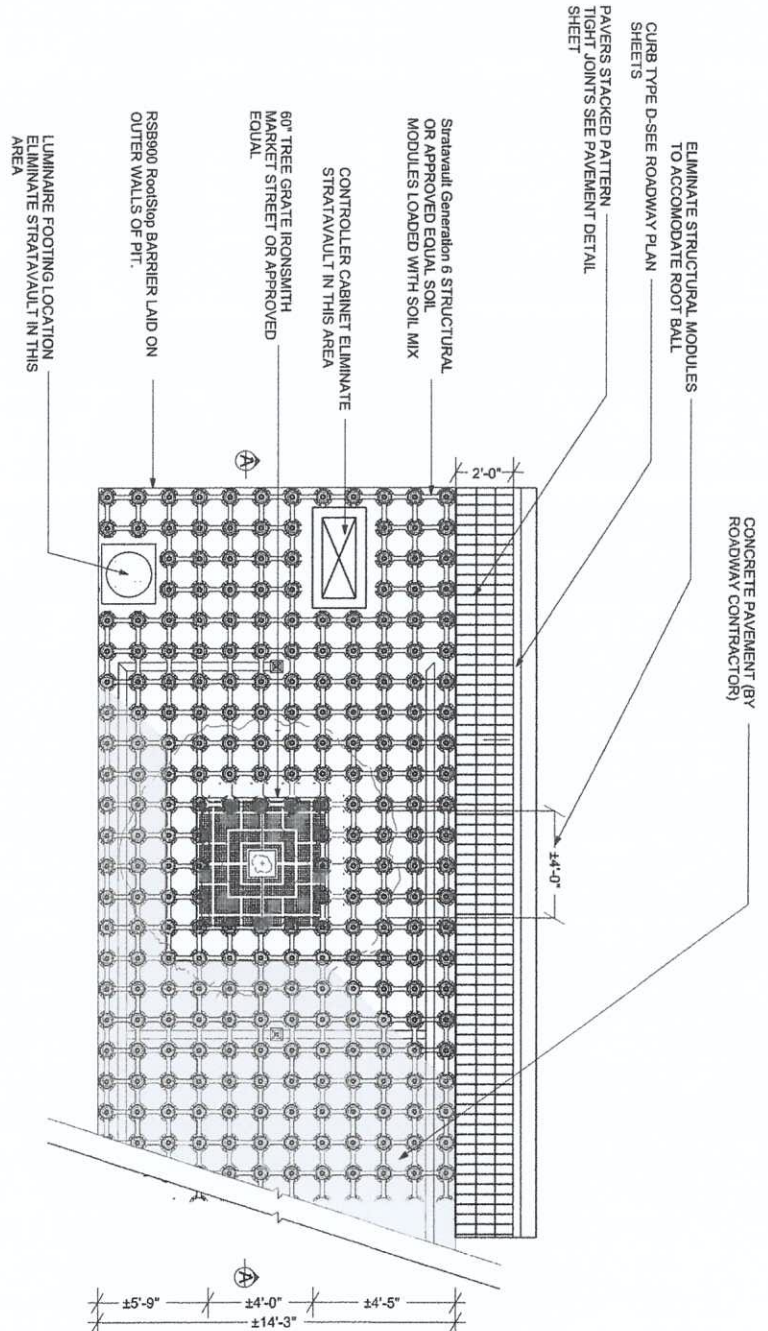

 HNTB ARCHITECT OR RECORD, CHRISTOPHER O. KELLER 4011 S. RAINBOW ROAD SUITE 300 JACKSONVILLE, FLORIDA 32206 CA NUMBER: 6590 NA No. 000110	JACKSONVILLE TRANSPORTATION AUTHORITY SW BRT CORRIDOR 6/17/2019 5:06:18 PM	PARK ST. / JACKSON ST. LANDSCAPE PLAN SHEET (8) SHEET NO. 100
---	--	---



TREEPIT - PARTIAL CUT-AWAY/PLAN

NTS

DATE	REVISIONS	DESCRIPTION	SHEET NO.
			101

 	 4651 SALTWOOD ROAD SUITE 200 JACKSONVILLE, FLORIDA 32256 PHONE: 904.250.5900 FAX: 904.250.5909 CA NUMBER: 6300	ARCHITECT OF RECORD: CHRISTOPHER O. KELLER R.A. NO. 0001312	JACKSONVILLE TRANSPORTATION AUTHORITY SW BRT CORRIDOR 3/28/2019 6:57:00 PM	LANDSCAPE DETAIL SHEET (1)
--	--	--	--	-------------------------------

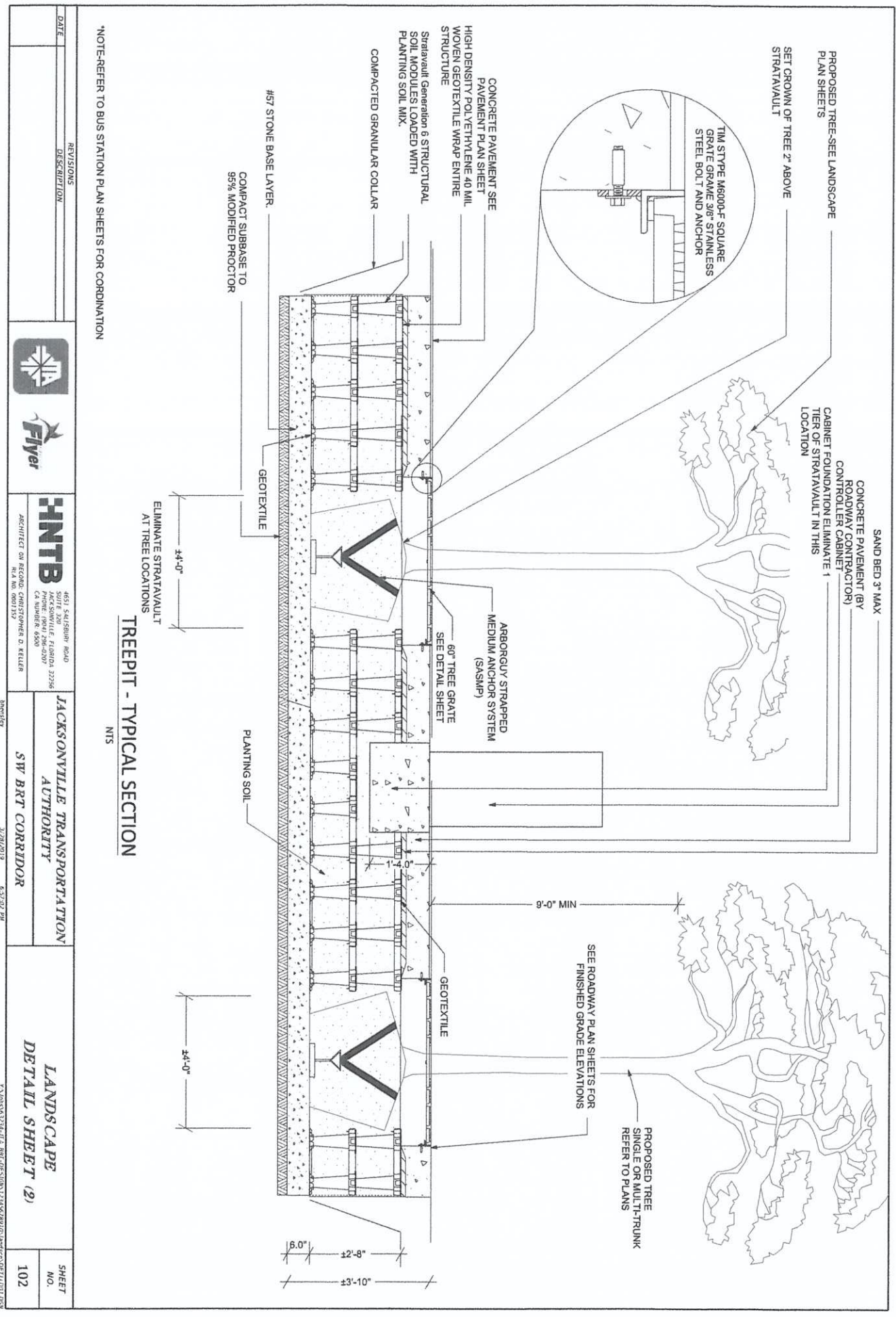

DATE	REVISIONS			4651 SALTBRINE ROAD SUITE 300 JACKSONVILLE, FLORIDA 32206 PHONE: 904-786-7500 FAX: 904-786-7500 CA NUMBER: 6500	JACKSONVILLE TRANSPORTATION AUTHORITY	SW BRT CORRIDOR	LANDSCAPE DETAIL SHEET (2)	SHEET NO.

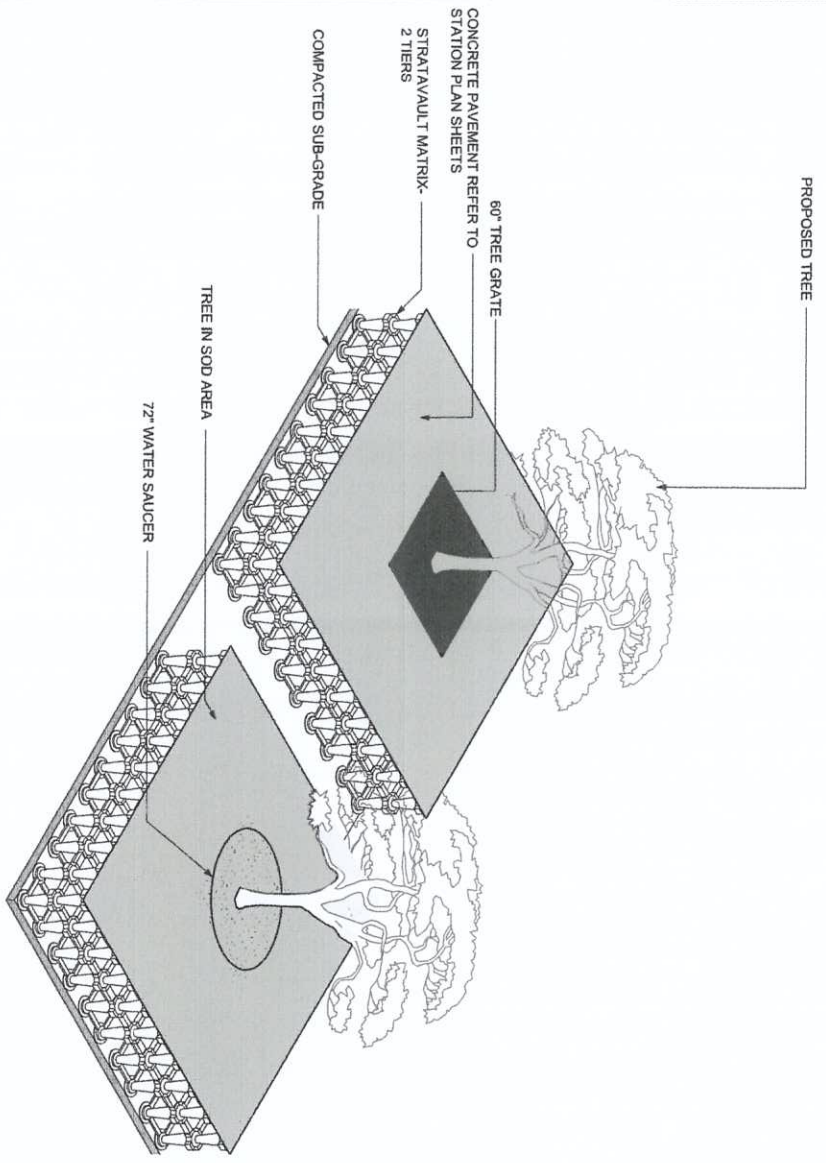

TREEPIT - ISOMETRIC ELEVATION
NTS

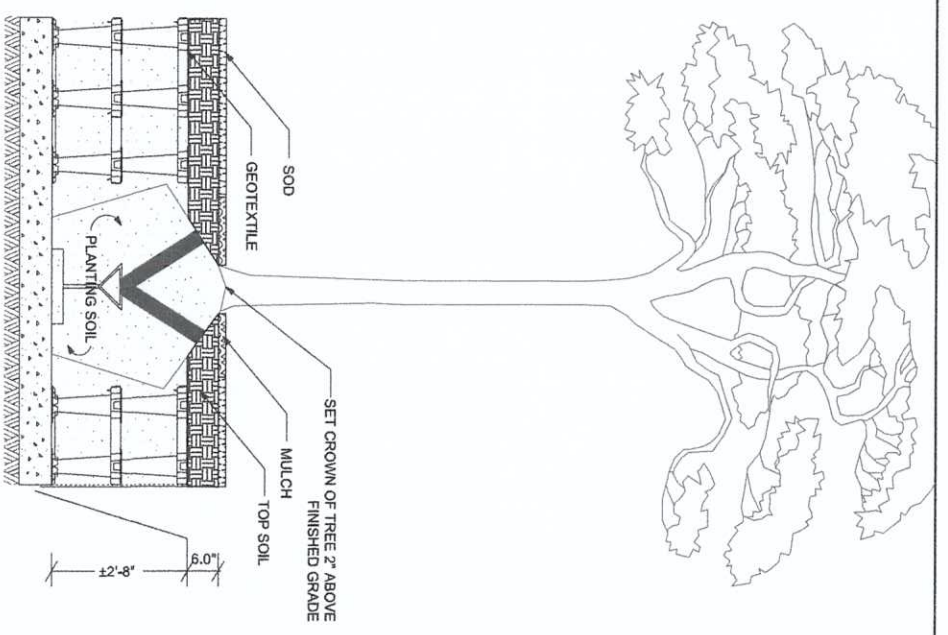

ALTERNATE PLANTING DETAIL
TREE IN SOD AREA
NTS

REVISIONS		DATE	DESCRIPTION

 HNTB SUITE 300 JACKSONVILLE, FLORIDA 32208 CA NUMBER: 6300 ARCHITECT OR RECORD: CHRISTOPHER D. KELLER FLA NO. 0001313	JACKSONVILLE TRANSPORTATION AUTHORITY SW BRT CORRIDOR	4651 SALSBUROUGH ROAD SUITE 300 JACKSONVILLE, FLORIDA 32208 CA NUMBER: 6300 ARCHITECT OR RECORD: CHRISTOPHER D. KELLER FLA NO. 0001313	LANDSCAPE DETAIL SHEET (3)	SHEET NO. 103

PROJECT: SW BRT CORRIDOR
 DATE: 3/28/2019
 TIME: 6:57:02 PM
 USER: A234713.BRT-DESIGN\234678910\andrea.vietti1031.dwg

Vertical constraints for planted trees with medium and large ultimate stature:

The origin, path, and extent of growth of the above-ground portion of a planted tree should be compatible with above ground utilities, other trees, traffic sight lines, buildings, and other features of the vertically-engineered environment. Trees originating from soil volumes next to vertical constraints must grow at an angle, and the resulting canopy encroaches upon those vertical constraints more than trees growing in centralized medians. This path can be corrected with early-life-stage maintenance pruning in small diameter branch wood, releasing the tree to gain height and spread at the most available sunlight gap.

The effect of proactive maintenance cuts on young planted trees is not singular; 1.) *Cost savings* - factoring in the entire workflow of travel time associated with reactive pruning, heavier equipment needs, debris yardage and associated dump fees, pruning a 1" diameter branch is much cheaper than pruning a 4" diameter branch, which is much cheaper than removing the same branch decades later when it is 15" diameter. Proactively pruning several trees immediately adjacent to each other amplifies these cost savings. Along with the cost savings, 2.) *Better tree health and structure* - small pruning wounds compartmentalize faster and permit a much smaller decay column to penetrate vertically into the middle of the adjacent branch or trunk. 3.) *The accrual of efficiency* - Young trees have few constraints on where the main leader can be directed to, thus heading off the compounding negative effects of pruning later on. 4.) *Mental wellness* – Trees that are well cared for convey a sense of pride. This is mental state is not only above the neutral state of feeling ambivalent, but is twice the gain over the experience of living next to trees subjected to multiple low limb removals and little or no ANSI A300-standard maintenance.

In some cases, it is more cost effective to not maintain a planted tree – trees in natural areas, and trees in expansive medians such as this one below:



There is, however, a very small list of trees that grow in urban spaces that are more confined without some assistance from pruning; Italian cypress (*Cupressus sempervirens*), *Liquidambar styraciflua* 'Slender Silhouette' sweetgum, and pine anchor the list. The next most excurrent trees such as tulip poplar (*Liriodendron tulipifera*), and bald cypress (*Taxodium distichum*) almost always require at least some pruning to keep them away from adjacent structures and other trees. Seedling southern live oak are not among this group – they are decurrent trees that will spread into available space, and cast low branches that die in shade when ensconced between other trees or buildings. Southern live oak cultivars with acute junctions ('Highrise' and 'Cathedral') as well as some elm species also require some encroachment pruning, but they accrue structural issues (bark stuck in the acute-angled branch unions inhibits the attachment of the branches to each other) similar to those present in Bradford pear. With wood that is much more dense and a larger ultimate stature, southern live oak cultivars become liabilities over time. The lifelong structural, health, and aesthetic drawbacks of these cultivars outweigh the fascination with them at the project design and installation phases. Most of us want to see more than a handful of excurrent cultivars and species in our urban surroundings, and we are available to consider cost-effective measures that lead to better outcomes for newly planted trees.

The standard for planted trees with more vertical constraints could include some or all of the following:

Design phase:

- a. Note the planned ultimate size of the tree, including DBH and crown spread.
- b. Note the presence of buildings or other vertically engineered structures adjacent to planting site: none, 1-2 stories, >2 stories high.
- c. Note presence of overhead utilities and traffic infrastructure.
- d. Note whether proposed planting is centered in a median in the middle of the street between structures, at a corner between the street and a structure, or in a planting bed between the street and a structure.
- e. Note conflicts between proposed ultimate size of tree and vertical constraints.
- f. Include a maintenance plan for a natural pruning system to develop and maintain:
 - i. A tree with a dominant trunk and well-spaced scaffold branches with diameters subordinated to an aspect ratio of 3:2 (dominant:scaffold) or less (e.g. 2:1, 3:1) with respect to the dominant trunk.
 - ii. A pruning frequency that enables pruning to be reduction cuts in 2-4" diameter branch wood.
 - iii. Clearance achieved by directional pruning with respect to pedestrians (8'), vehicles (18' for scaffold limbs, 14' for small branches, dimensions as specified by Traffic and Engineering for lines of sight), buildings (minimum of 4'), and other trees.

Procurement and Installation phase:

As described elsewhere.

Maintenance phase:

- a. Maintain according to specifications (appended) for trees with vertical constraints:

1. Young trees planted in the last 5 years
2. Young trees planted in the last 10-15 years
3. Trees planted more than 15 years ago

SECTION 144
LANDSCAPING
Excerpts regarding irrigation

GENERAL

MATERIALS

Sections 144.22 – 144.24

PORTABLE WATER BAG: UV treated polyethylene “Ooze Tube” 35 gallon portable water bag, chocolate brown color, from Engineered Watering Solutions (www.engineeredwatering.com, Atlanta, GA. Kit includes wood stake and water emitters.

TEMPORARY IRRIGATION SYSTEM: A run of PVC pipe and emitters with a water connection constructed to deliver water from a water truck or fire hydrant to a cluster of plants. Piping may be laid on the soil surface or buried in the soil. Remove the temporary water system at the end of the maintenance period.

WATER

- A. Provide water of suitable quality for healthy plant growth.
- B. The contractor shall pay for the cost of irrigation water used during construction, through the Initial Acceptance of the landscaping, during the plant establishment period, and until Final Acceptance. The cost of irrigation water shall be included in the unit price of each plant.

EXECUTION

Section 144.39

WATERING AFTER INSTALLATION

- A. General: Water soil sufficiently to keep plant roots moist, but not saturated, to prevent wilting, and to keep plants healthy. (The Agriculture Extension Service recommends watering daily for at least one month after installation during the growing season when there is no rain or 2 to 3 times a week during the winter and rainy weather). Following rainfall, delay watering until all free moisture has drained from the soil.
- B. After initial watering, provide water to trees and palms using water bags and/or a temporary irrigation system that will provide to each tree or palm during each watering the volume of water shown in the *Table 2* below. Water other plants with a temporary irrigation system or, if approved by the Contract Manager, use the existing irrigation system.
- C. If water bags are used to water trees and palms, place water bag around the trunk and fill with 35 gallons of water with each watering in accordance with manufacturer’s instructions. Install 4 emitters to provide a slow water drip over one week. **Fill water bags once a week during the first 6 weeks after installation and thereafter at a frequency necessary to keep plants in healthy condition.**
- D. If a temporary irrigation system is used, connect the system to a water truck or other water source and pump water until the specified volume of water in the tables 2 and 3 below is delivered to each plant through emitters. Apply at a rate that will allow the water to soak into the root ball without runoff.
- E. Maintain each temporary or permanent irrigation system and each water bag in working condition throughout the installation and maintenance period and until Final Acceptance. Immediately repair or replace each water bag or temporary irrigation system component that is missing or malfunctioning.
- F. Apply the volume of water shown in Table 2 and 3 each time plants are watered, unless water bags are used. Schedule watering frequency necessary to keep plants in healthy condition, with no wilting.

Table 2		WATER VOLUME FOR NEW TREES & PALMS	
Single Trunk Tree Caliper	Multi-trunked Tree Ht.	Min. Water Volume Per Application	
2" Cal.	8-10'	4 Gal.	
3" Cal.	10-12'	6 Gal.	
4" Cal.	12-14'	8 Gal.	
5" Cal.	14-16'	10 Gal.	
6" Cal.	-	12 Gal.	
Each Palm	-	12 Gal.	

TABLE 3		WATER VOLUME FOR NEW SHRUBS & GROUNDCOVERS	
Plant Size	*Min. Water Volume Per Application		
1 Gallon	1 quart		
3 Gallon	2 quarts		
7 Gallon	1 gal.		

*If shrubs and groundcovers are located within a multiple plant bed, apply ½ to ¾" of water throughout the plant bed during each watering in lieu of watering each individual plant.

- G. If a permanent automatic irrigation system is located within new turfgrass areas or multiple plant beds, the Contractor may seek the approval of the Contract Manager to use the existing irrigation system and to delete a temporary irrigation system and hand watering, provided that such request is made before beginning planting work. If the Contract Manager determines that there is sufficient capacity to provide the specified water volume to the area and approves the Contractor's use of the existing irrigation system, the City will modify the irrigation system to provide uniform water distribution throughout the turf area or plant bed before planting work begins.























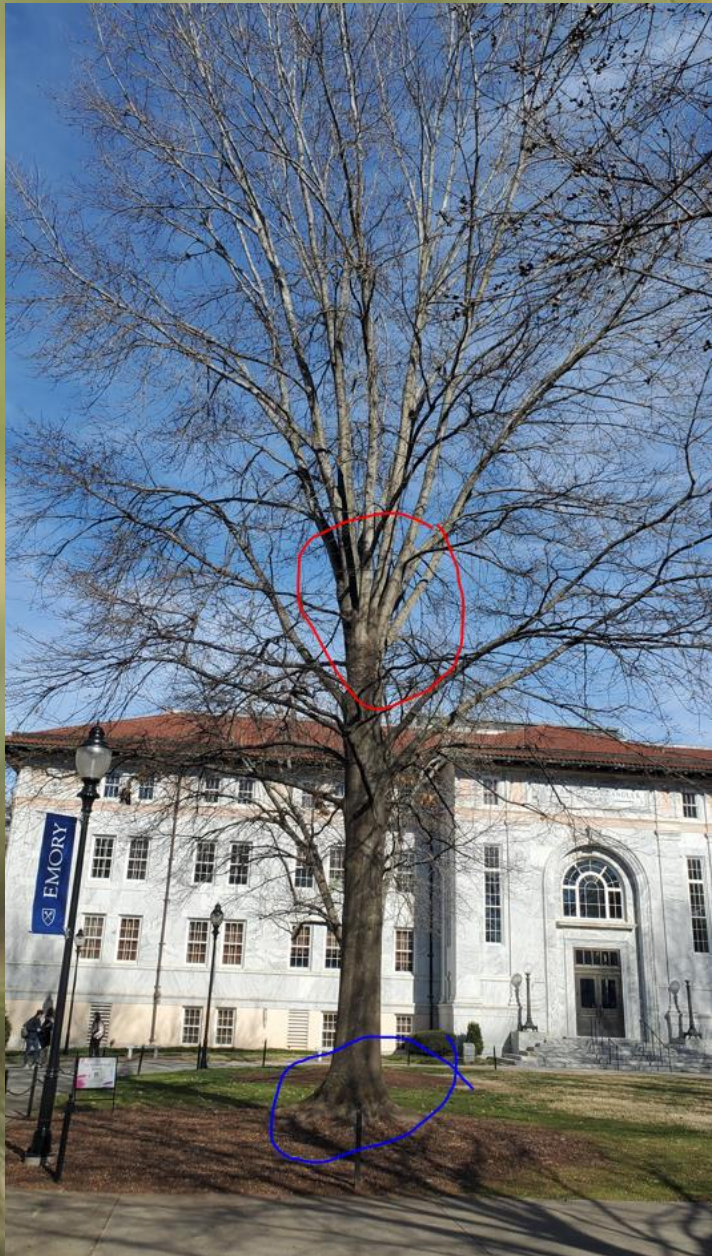

























BRINGING ORDER TO THE TECHNICAL DYSFUNCTION WITHIN THE URBAN FOREST¹

by James Urban

In order to increase the success rate of trees planted in the urban environment, there must be a significant change in the way trees are planted. The wide diversity in soil conditions found within urban areas suggests that there should be modifications to planting details from one site to another. The profession of urban forestry and landscape architecture, however, continue to use the same planting details regardless of the quality of the existing soil. Further, no protocol exists to guide the decision making process to determine when to use different methodologies.

This paper will present the framework for such a methodology and a series of possible changes to the way trees should be planted. The methodology is based on quantifiable levels of urbanization and soil quality, and proposes a logical approach to the design of planting details.

A major impasse to the development of a healthy urban forest is the technical dysfunction within the professions of urban forestry and landscape architecture with respect to the details of planting trees. The average professional knows little about how a tree actually grows. They are not skilled in the mechanics and dynamics of soil, roots and water and they are not aware of the impact these dynamics have on performance. Current planting practices are designed for the most benign sites; where soil is generally suitable to support root growth, is well drained, and is available in large quantities. Unfortunately, the urban forest is a continuum of soil conditions which range from these good sites to sites that have little or no drainage and where the soil is of such inferior quality and structure that it will not allow root penetration or function.

Urban forestry practices have largely relied on tree selection or "the right tree in the right place" as the primary method to overcome more difficult

sites. Current research suggests that many urban sites are so severe that no species will reliably work. Modification of the site soil and drainage capability is often the only solution to successful growing of trees. On better sites, modification of the planting area could be used to broaden the number of species that will be predictably successful.

Predictability and success are the key words. When a professional forester or landscape architect is relied upon to specify a tree planting, the person investing in the cost of the tree should have some reasonable assurance that the tree will grow to meet some predetermined level of success. It is one of our profession's obligations to either ensure that the site is made suitable for the trees' growth potential or to define for our clients how much growth they should expect out of a given tree in a given site.

Site modification, however, is expensive and requires specific solutions for each problem. Currently, there are few guidelines or standards to assist in the designing of site modification procedures. Practitioners who attempt to propose new planting details are often viewed as extravagant and individual designers often come up with widely varying solutions to similar problems. The following protocol is proposed to begin to set standards for site modification and the design of planting sites. It is designed as a guide to help predetermine how much site modification is necessary to successfully grow large trees. The protocol is based on the principle that soil is the primary factor influencing tree growth in urban areas. It is necessary for a tree to have access to sufficient rooting space in order to grow properly. Since both soil quality and soil quantity are critical to the equation, a methodology is proposed to accommodate each factor.

1. Presented at the annual conference of the International Society of Arboriculture in Philadelphia in August 1991.

Site Modification Protocol

Step one - *Determining Soil Quality*. Soil quality is primarily a function of how much the soil has been graded or disturbed and how much the soil has been compacted. Each site (or portion of the site) should be evaluated to predict what the condition of the soil will be after construction is completed. While soil quality is a continuum, the protocol will establish four classifications of soil quality as follows: 1) not graded and not compacted, 2) not graded but compacted, 3) graded but not compacted, 4) graded and compacted (Figure 1).

Definitions. The term *graded* is defined as a soil that has had its 'A' horizon disturbed, removed and not replaced or a soil that has had its 'A' and 'B' horizon moved from one location to another. The term *compacted* is defined as a soil that has been compressed to a bulk density which prohibits root growth (greater than 1.6 gr/cm). it is very difficult to predict how much the construction process will compact soil. Worse case assumptions should be used.

Step two- *Determining Level of Urbanization*. The second soil factor affecting tree growth is the quantity of soil available to the tree. This protocol chooses to measure urbanization or the aggregate of total development on a site, as an effective measuring gauge of the amount of soil "likely" to be available. Urbanization actually affects two important elements. One, the amount of soil left as available to the tree, and two, the amount of resources available

per tree to modify the planting site. The higher the intensity of use of a site, the more money that may be spent on tree planting. Urbanization, like soil disturbance, is a continuum. For the purpose of this protocol, levels of urbanization will be defined based on the % of impervious surface remaining after construction, as follows: 1) less than 15%, 2) 15% - 50%, 3) 50% - 75%, 4) 75% - 90%, 5) 90% or greater (Figure 2).

Step three - *Find the Sites Minimum Design Criteria*. Soil disturbance and urbanization are put on the axis of the Minimum Design Criteria Matrix (Figures 3 & 4). In each of the resulting 20 positions are recommendations for minimum design criteria to be used when preparing planting details. The recommendations are made for the three critical design elements that affect tree growth. These are soil modification, drainage modification and aeration modification. The recommendations are made using a numerical code which is referenced in the following sections. By using these criteria, minimum details can be developed. Not all situations, however, will match these criteria. If conditions exist which suggest that a different criterion would be more appropriate, then it may be substituted provided that the designer understands the impact on the tree of this change.

Soil Modification Procedures

The following list describes optional methods of soil modification that can be included into planting

SOIL QUALITY

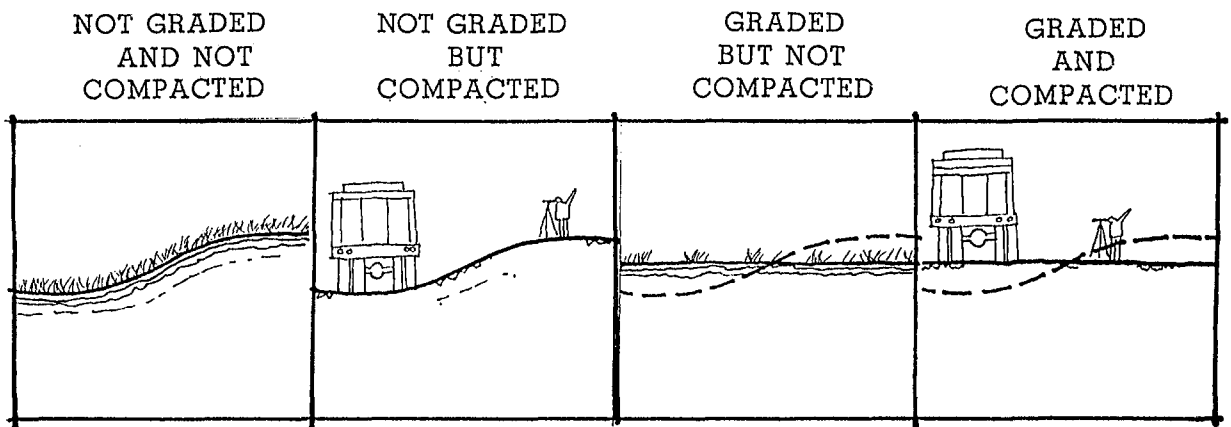

Figure 1

URBANIZATION % IMPERVIOUS SURFACE

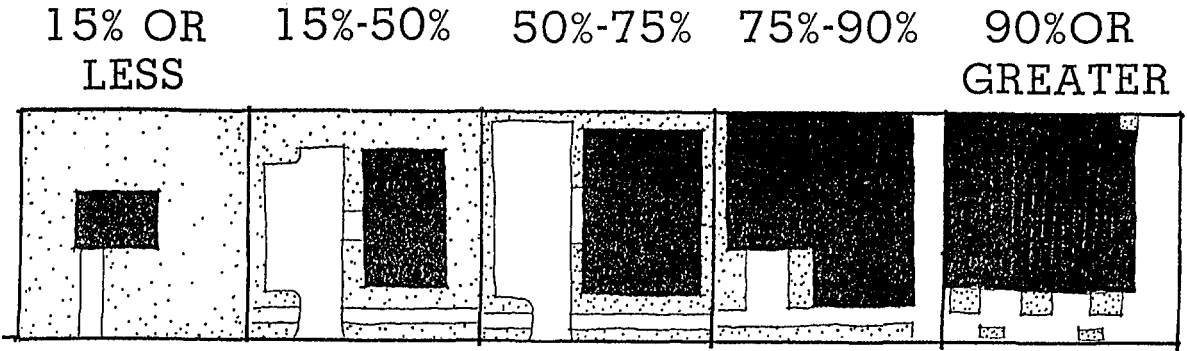

Figure 2

details. They are ranked from the least to the most complex of procedures. Providing enough soil, of suitable quality to support the tree mass proposed in a given location must be accounted for in the earliest phases of the project. (The codes refer to Figure 4.)

- S1.** Dig the planting hole 60 cm (24 in) larger in diameter than the diameter of the root ball. Back fill with the unamended soil excavated from the hole
- S2.** Dig the planting hole 180 cm (6 ft) larger in diameter than the diameter of the root ball.

MINIMUM DESIGN CRITERIA MATRIX GUIDE

URBANIZATION % IMPERVIOUS SURFACE		URBANIZATION % IMPERVIOUS SURFACE				
		15% OR LESS	15%-50%	50%-75%	75%-90%	90% OR GREATER
SOIL QUALITY	NOT GRADED AND NOT COMPACTED					
	NOT GRADED BUT COMPACTED		Block #	9	D	Drainage
			Soil	S	A	Aeration
	GRADED BUT NOT COMPACTED					
	GRADED AND COMPACTED					

Figure 3

- Back fill with the unamended soil excavated from the hole.
- S3.** Dig the planting hole 180 cm (6 ft) larger in diameter than the diameter of the root ball. Excavate the remaining areas of soil in planters and lawn to a depth of 20 cm (8"). Till the resulting subgrade with the first 10-15 cm (4-6 in) of planting soil mix.
- S4.** Excavate all areas available for planting and lawn to a depth of 75 cm (2.5 ft). Till the resulting subgrade with the first 10-15 cm (4-6 in) of planting soil mix. Calculate the quantity of planting soil mix to determine that the volume of soil per tree being provided is sufficient to grow the tree specified (Figure 5). Modify the design to allow for adequate soil volume.
- S5.** Perform the requirements of Step S4. Design additional subsurface soil volumes below the adjacent paving as required to provide all adequate soil volume (Figure 5). Interconnect these soil volumes whenever possible.

Definitions:

Planting soil mix. A sandy loam comprised of a majority of medium to coarse sands. This soil should have a percolation rate when fully compacted of at least 2 inches per hour.

Soil volume. All soil that is available to the roots of the tree that is of suitable quality for root

MINIMUM DESIGN CRITERIA MATRIX

URBANIZATION
% IMPERVIOUS SURFACE

15% OR
LESS

15%-50%

50%-75%

75%-90%

90% OR
GREATER

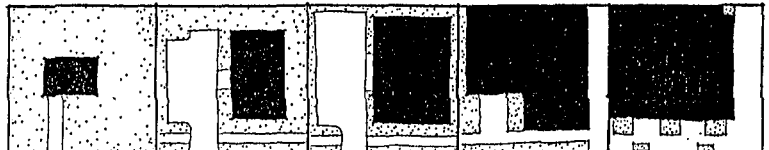

SOIL QUALITY

NOT GRADED
AND NOT
COMPACTED

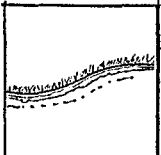

1

D1

3

D1

6

D1

10

D2

14

D2

S1

A1

S1

A1

S2

A1

S2

A2

S3

A2

NOT GRADED
BUT
COMPACTED



2

D1

5

D1

9

D2

13

D2

17

D3

S1

A1

S2

A1

S2

A2

S3

A2

S4

A3

GRADED
BUT NOT
COMPACTED



4

D1

8

D2

12

D2

16

D3

19

D3

S1

A1

S2

A2

S3

A2

S3

A2

S5

A4

GRADED
AND
COMPACTED



7

D2

11

D2

15

D2

18

D3

20

D3

S2

A2

S3

A2

S4

A2

S4

A3

S5

A4

Figure 4

growth (well drained, not compacted, and possessing adequate pore space). The maximum depth for this calculation is normally 75 cm (2.5 ft).

Drainage Modification Procedures

The following list describes optional methods of drainage modification that can be included in planting details. They are ranked from the least to the most complex of procedures. Adequate drainage is required to obtain root growth in the soil. Soil modification without attention to drainage can lead to saturated soils that will not support tree growth. (The codes refer to Figure 4.)

D1.1. Percolation of existing soil 5 cm (2 inches) per

hour or greater. Provide positive surface drainage, minimum of 2%.

D1.2. Percolation of existing soil 2.5-5 cm (1-2 inches) per hour. Increase surface slopes in planting areas to 10% away from the tree.

D1.3. Percolation of existing soil less than 2.5 cm (1 inch) per hour. Mound planting soil in the area of the tree at 20% so that the root ball is entirely above the existing grade and/or add subsurface drain lines around the tree and loosen the soil to a depth of 30 cm (12 in).

D2. Unpredictable percolation. Move existing water away from the site by providing subsurface drain lines within the planting area and/or provide a drain sump pit at each tree. Perform a percola-

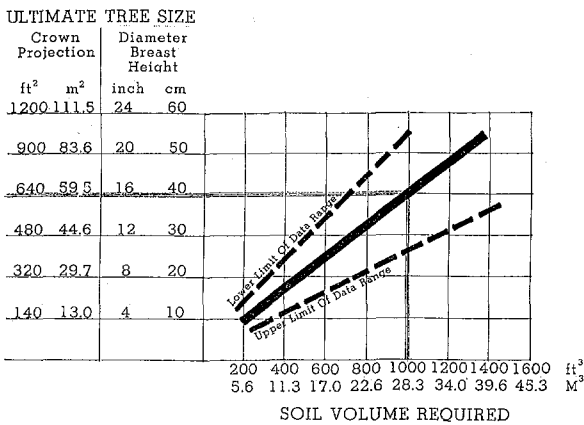

Figure 5. The data on this chart represent a synthesis of several studies attempting to establish the relationship between tree growth and soil volume. See citations 7,8,9,13.

tion test at each tree. Apply criteria of D1.1 - D1.3 above.

D3.1. Trees within new paving, provide subsurface drain lines to remove water from the site which connect from tree to tree.

D3.2. Trees within existing paving, perform a percolation test. If the percolation of the existing soil is 2.5 cm (1 in) per hour or greater, install drainage sump with subsurface drain line ring around the tree. If the percolation of the existing soil is less than 2.5 cm per hour, **do not plant** the tree unless drainage can be improved.

Definitions

Percolation test. Dig a hole 15 to 25 cm (6 - 10 inches) in diameter and 25 cm deep, fill the hole with water and allow it to drain. Refill the hole with water and measure the rate of water percolation out of the hole.

Drainage sump. A hole 20 to 30 cm (8 - 12 inches) in diameter by at least 1 m (3 ft) deep measured from the bottom of the planting hole. Insert a 10 cm (4 inches) diameter perforated pipe which extends up to grade and backfill with coarse gravel. Drainage sumps are only effective if they reach a pervious layer.

Aeration Modification Procedures

The following list describes optional methods of aeration modification that can be included in

planting details. They are ranked from the least to the most complex of procedures. The ability of soils to conduct air to the root zone is critical. Where soil volumes are restricted, new details, which allow more air to get deeper into the soil, will greatly increase the effectiveness of the available soil. (The codes refer to Figure 4.)

- A1.** Provide for periodic aeration and/or mulching of the ground within the dripline of the tree.
- A2.** Provide aeration sheets along accessible surfaces, i.e., foundations, curbs, etc.
- A3.1.** With existing paving, provide aeration sheets within the planting area.
- A3.2.** With new paving, provide aeration sheets within the planting areas and under paved areas. Install coarse gravel subbase under all paved areas. Install open joint unit pavers where applicable.
- A4.** Install watering tubes within the gravel subbase plus provide A3 requirements.

Definitions

Aeration sheets. Three dimensional drainage cores covered on both sides with a geotextile fabric. The sheets should be 30 to 45 cm (1 -1.5 ft) wide and be placed in a vertical position in order to be effective. Aeration sheets are currently made by: American Enka Co., Enka, NC (Enka Drain # 9228); American Wick Drain Corp., Matthews, NC (Akwa Drain 112) and Mirafi Corp., Charlotte, NC (Miradrain 4000).

Watering tubes. Five cm (2 in) diameter perforated tubes that conduct water from a surface source into the gravel under the paving.

Other Determinants That Affect Tree Growth

There are a number of other factors that affect planting detail design but are not easily accounted for in this protocol. Each of these will have to be considered by the designer and appropriate modifications to the recommendations must be considered.

Soil Texture. Extremes of very sandy, silty or clayey soils are not accounted for in this protocol. When these soils are encountered, follow the recommendations of a soil scientist.

Soil Profile. Unusual soil profiles such as fragipans, hardpans, shallow rock formations or under-

ground structures will require special details.

Site History. The age of the buildings and site work can have a significant impact on the opportunities for root growth. Sites developed prior to 1940 may require less site modification to grow successful trees due to the differences in the way land was developed. Sites that have had several changes in the configuration of buildings and grades may require more site modifications than may be indicated by the protocol. Each layer of change introduces disruption to the soil structure that is often hard to determine by visual site inspection.

Project Maintenance. These recommendations assume that some minimum maintenance will be available on a long term basis. This would include regular pruning, watering during the initial transplant period, and some ongoing insect and disease control. Less maintenance will require more site modification to grow similarly sized trees while more maintenance, particularly irrigation and fertilization, will allow for slightly less site modification.

Conclusions

The state of urban forestry must continue to evolve if successful urban forests are to be grown and maintained. New partnerships and institutions will have to be forged and new standards will have to be set. Much of the technical information we currently rely on will have to be set aside in favor of new ideas that will be based on research and documented experience. The protocol for tree planting detail design outlined above is only one small step in this process.

Literature Referenced or Cited

1. Berrang, Paul, David Karnosky and Brian J. Stanton. 1985. *Environmental factors affecting tree health in New York City*. J. Arboric. 11 (6): 185-189.
2. Craul, Phillip J. 1982. Introduction to basic soil properties and their characteristics. Urban Forest Soils, a reference workbook. SUNY College of Environmental Science and Forestry.
3. Craul, Phillip J. 1985. *A description of urban soils and their desired characteristics*. J. Arboric. 11(11): 330-339.
4. Evans, Matthew, Nina Bassuk and Peter Throwbridge. 1990. *Sidewalk design*. Landscape Architecture Magazine 80(3):
5. Kays, Barrett L. and James C. Patterson. 1982. Soil drainage and infiltration. Urban Forest Soils, a reference workbook, SUNY College of Environmental Science and Forestry.
6. Kopinga, Jitze. 1985. Research on street tree planting practices in the Netherlands. Proc Fifth Conference of the Metropolitan Tree Improvement Alliance.
7. Lindsey, Patricia and Nina Bassuk. 1991. *Specifying soil volumes to meet the water needs of mature trees in containers*. J. Arboric. 17: 141-149.
8. Perry, Thomas O. 1985. Planting site for a three inch caliper tree with room to grow. Proc Fifth Conference Metropolitan Tree Improvement Alliance.
9. Perry, Thomas O. 1989. Conditions for plant growth. Proc. Fourth Urban Forest Conference, St. Louis, Missouri.
10. Rakow. 1989. Determining adequate rooting space for trees in planters or in the ground. Proc Sixth Conference Metropolitan Tree Improvement Alliance.
11. Spomer, Art L. 1989. Soil limits in the landscape. Proc Sixth Conference Metropolitan Tree Improvement Alliance.
12. Urban, James R. 1989 Evaluation of tree planting practices in the urban landscape. Proc. Fourth Urban Forest Conference, St. Louis, Missouri.
13. Urban, James R. 1989. *New techniques in urban tree plantings*. J. Arboric. 15(11): 281-284.

*Landscape Architect
Urban and Associates
915 Creek Drive
Annapolis, Maryland 21403*

Bringing Order to the Technical Dysfunction within the Urban Forest
James Urban ISA Annual Conference, 1991

Current planning practices are designed for the most benign sites; where soil is generally suitable to support root growth, is well drained, and is available in large quantities.

Unfortunately, the urban forest is a continuum of soil conditions which range from these good sites to sites that have little or no drainage and where soil is of such inferior quality and structure that it will not allow root penetration or function.

Urban forestry practices have largely relied on tree selection or the "right tree in the right place" as the primary method to overcome more difficult sites.

Current research (1991) suggests that many urban sites are so severe that no species will reliably work.

Modification of the site soil and drainage is often the only solution to successful growing of trees.

On better sites, *modification of the planting area* could be used to broaden the number of species that will be predictably successful.

When a professional forester or landscape architect is relied upon to specify a tree planting, the person investing in the cost of the tree should have some reasonable assurance that the tree will grow to meet some predetermined level of success.

GUIDE TO HELP PREDETERMINE HOW MUCH SITE MODIFICATION IS NECESSARY TO SUCCESSFULLY GROW LARGE TREES.

Perform a conditions assessment (after construction is completed, or if infill, current conditions):

Soil Quality	Not Graded and Not Compacted Not Graded But Compacted Graded but Not Compacted Graded and Compacted
<i>Graded</i>	topsoil removed or disturbed and relocated on site
<i>Compacted</i>	compressed to a bulk density that prohibits root growth (worst case should be assumed)
Impervious Surface	less than 15% impervious 15% - 50 % impervious 50% - 75% impervious 75% - 90 % impervious over 90% impervious
<i>Degree of Urban</i>	percent of impervious surface remaining within mature canopy (dripline)

Identify the Minimum Design Criteria:

Soil Quantity Goal : provide enough soil, of suitable quality to support the tree mass proposed in a given location.

<u>Matrix Standards:</u>	S1	Dig the planting hole 24 inches larger in diameter than the root ball diameter. Backfill with unamended soil excavated from the hole.
	S2	Dig the planting hole 6 feet larger in diameter than the root ball diameter. Backfill with unamended soil excavated from the hole.
	S3	Dig the planting hole 6 feet larger in diameter than the root ball diameter. Excavate the remaining area of soil in planters and lawn to a depth of 8 inches. Till the resulting subgrade with the first 4-6 inches of planting soil mix.
	S4	Excavate all areas available for planting and lawn to a depth of 2.5 feet. Till the resulting subgrade with the first 4-6 inches of planting soil mix. Calculate the quantity of planting soil mix to determine that the volume of soil per tree being provided is sufficient to grow the tree specified. Modify the design to allow for adequate soil volume.
	S5	Perform the requirements of Step S4. Design additional subsurface soil volumes below the adjacent paving as required to provide all adequate soil volume. Interconnect these soil volumes when possible.

Planting Soil

a sandy loam comprised of a majority of medium to coarse sands. This soil should have a percolation rate when fully compacted of at least 2 inches per hour

Soil Volume

all soil that is available to the roots of the tree that is of suitable quality for root growth (well drained, not compacted, possessing adequate pore space). Maximum depth for this area is normally 2.5 feet.

Drainage Goal: Drainage adequate to obtain root growth in the soil.

<u>Matrix Standards:</u>	D1.1	Percolation of existing soil 2 inches / hour or greater. Positive surface drainage, min. 2%.
	D1.2	Percolation of existing soil 1- 2 inches / hour or greater. Increase positive surface drainage in planting areas to 10% away from the tree (mounding)
	D1.3	Percolation of existing soil less than 1 inch/ hour or greater. Mound planting soil in area at least 20% so rootball is entirely above existing grade OR add subsurface drain lines around tree and loosen soil to a depth of 12 inches.
	D2	Unpredictable percolation. Move existing water away from the site by providing subsurface drain lines within planting area and/ OR provide a drain sump pit at each tree. Perform perc test at each tree; apply D1.1, 1.2 or 1.3 criteria.
	D3.1	Trees within new paving, provide subsurface drain lines to remove water from the site which connect from tree to tree.

D3.2 Trees within existing paving, perform a perc test. If the perc of existing soil is 1 inch/hour or greater, install drainage sump with subsurface drain line in ring around tree. If perc is less than 1 inch/hour, do not plant trees unless drainage is improved.

Perc test

Dig a hole 6-10 in in diameter and 10 in deep; fill with water and allow to drain. Refill with water; measure the rate of water percolation out of the hole.

Drainage sump

A hole 8-12 inches dia by min. 3 foot depth*, measured from the bottom of the planting hole. Install a 4' perforated pipe extending to grade ; backfill with coarse gravel.*Depth must reach pervious layer.

Aeration Goal: Provide sufficient air to the root zone to address effectiveness of the available soil.

Matrix Standards:

- A1 Provide for periodic aeration and/or mulching of the ground within the dripline of the tree.
- A2 Provide aeration sheets along accessible surfaces (foundations and curbs)
- A3.1 Within existing paving, provide aeration sheets within the planting area.
- A3.2 With new paving, provide aeration sheets within the planting areas and under paved areas. Install coarse gravel subbase under all paved areas. Install open joint unit pavers were applicable / specified to achieve minimum pervious planting area.
- A4 Install watering tubes within the gravel subbase plus meet A3 requirements.

Aeration sheet

Three dimensional drainage cores covered on both sides with geotex fabric. Sheets to be 1-1.5 feet wide, placed vertically.

Watering tube

2 inch dia perforated tubes that conduct water from a surface source to the gravel under the paving.

Contributing Factors: Address as required:

- Soil Texture Very sandy, silty or clayey soils require recommendations of a soil scientist. Require ID of soils present to determine need for report/ consultation.
- Soil Profile Unusual soil profiles require special details (hardpan, shallow rock, **underground structures**).
- Site History Age of buildings and site work affects the likelihood of disrupted soil structure. Prior to 1940, site work resulted in less impact to the soil based on the way land was developed. Sites that have had several changes in configuration (grades and/or structures) may require more site modifications than indicated.
- Maintenance Recommendations all assume some minimum maintenance is available on a long term basis. This includes regular pruning, watering during initial grow-in period, and some ongoing insect and disease control. Less maintenance will require more site modification to grow similarly sized trees. More, particularly, irrigation and fertilizer, will allow for slightly less site modification.

Minumum Design Criteria Matrix

% Impervious		15% or Less Impervious		15% -50% Impervious		50%-70% Impervious		70% - 90% Impervious		90% or More Impervious	
Soil Quality	Not Graded AND	1	D1	3	D1	6	D1	10	D2	14	D2
	Not Compacted	S1	A1	S1	A1	S2	A1	S2	A2	S3	A2
	Not Graded BUT	2	D1	5	D1	9	D2	13	D2	17	D3
	Compacted	S1	A1	S2	A1	S2	A2	S3	A2	S4	A3
	Graded BUT	4	D1	8	D2	12	D2	16	D3	19	D3
	Not Compacted	S1	A1	S2	A2	S3	A2	S3	A2	S5	A4
	Graded AND	7	D2	11	D2	15	D2	18	D3	20	D3
	Compacted	S2	A2	S3	A2	S4	A2	S4	A3	S5	A4

source: Bringing Order to the Technical Dysfunction within the Urban Forest, Urban, 1991

Mitigation by Degree of Urbanization - Unconstrained to Highly Constrained

Unconstrained

Constraint Level 1 - Not Graded and Not Compacted / 15% or Less Impervious

Constraint Level 2 - Not Graded BUT Compacted / 15% or Less Impervious

Constraint Level 3 - Not Graded and Not Compacted / 15% - 50% Impervious

Constraint Level 4 - Graded and Not Compacted / 15% or Less Impervious

- S1** Dig the planting hole 24 inches larger in diameter than the root ball diameter. Backfill with unamended soil excavated from the hole.
- D1.1** Percolation of existing soil 2 inches / hour or greater. Positive surface drainage, min. 2%.
- D1.2** Percolation of existing soil 1- 2 inches / hour or greater. Increase positive surface drainage in planting areas to 10% away from the tree (mounding)
- D1.3** Percolation of existing soil less than 1 inch/ hour or greater. Mound planting soil in area at least 20% so rootball is entirely above existing grade OR add subsurface drain lines around tree and loosen soil to a depth of 12 inches.
- A1** Provide for periodic aeration and/or mulching of the ground within the dripline of the tree.

Urban 1

Constraint Level 5 - Not Graded BUT Compacted / 15% - 50% Impervious

Constraint Level 6 - Not Graded and not Compacted / 50% - 70% Impervious

- S2** Dig the planting hole 6 feet larger in diameter than the root ball diameter. Backfill with unamended soil excavated from the hole.
- D1.1** Percolation of existing soil 2 inches / hour or greater. Positive surface drainage, min. 2%.
- D1.2** Percolation of existing soil 1- 2 inches / hour or greater. Increase positive surface drainage in planting areas to 10% away from the tree (mounding)
- D1.3** Percolation of existing soil less than 1 inch/ hour or greater. Mound planting soil in area at least 20% so rootball is entirely above existing grade OR add subsurface drain lines around tree and loosen soil to a depth of 12 inches.
- A1** Provide for periodic aeration and/or mulching of the ground within the dripline of the tree.

Urban 2

Constraint Level 7 - Graded and Compacted / 15% or Less Impervious

Constraint Level 8 - Graded BUT Not Compacted / 15% - 50% Impervious

Constraint Level 9 - Not Graded BUT Compacted / 50% - 70% Impervious

Constraint Level 10 - Not Graded and Not Compacted / 70% - 90% Impervious

- S2** Dig the planting hole 6 feet larger in diameter than the root ball diameter. Backfill with unamended soil excavated from the hole.
- D2** Unpredictable percolation. Move existing water away from the site by providing subsurface drain lines within planting area and/ OR provide a drain sump pit at each tree. Perform perc test at each tree; apply D1.1, 1.2 or 1.3 criteria.
- A2** Provide aeration sheets along accessible surfaces (foundations and curbs)

Mitigation by Degree of Urbanization - Unconstrained to Highly Constrained

Urban 3	Constraint Level 11 - Graded and Compacted / 15% - 50% Impervious	
	Constraint Level 12- Graded BUT Not Compacted / 50% - 70% Impervious	
	Constraint Level 13 - Not Graded BUT Compacted / 70% - 90% Impervious	
	Constraint Level 14- Not Graded and Not Compacted / 90% or More Impervious	
	S3	Dig the planting hole 6 feet larger in diameter than the root ball diameter. Excavate the remaining area of soil in planters and lawn to a depth of 8 inches. Till the resulting subgrade with the first 4-6 inches of planting soil mix.
	D2	Unpredictable percolation. Move existing water away from the site by providing subsurface drain lines within planting area and/ OR provide a drain sump pit at each tree. Perform perc test at each tree; apply D1.1, 1.2 or 1.3 criteria.
	A2	Provide aeration sheets along accessible surfaces (foundations and curbs)
Urban 4	Constraint Level 15 - Graded and Compacted / 50% - 70% Impervious	
	S4	Excavate all areas available for planting and lawn to a depth of 2.5 feet. Till the resulting subgrade with the first 4-6 inches of planting soil mix. Calculate the quantity of planting soil mix to determine that the volume of soil per tree being provided is sufficient to grow the tree specified. Modify the design to allow for adequate soil volume.
	D2	Unpredictable percolation. Move existing water away from the site by providing subsurface drain lines within planting area and/ OR provide a drain sump pit at each tree. Perform perc test at each tree; apply D1.1, 1.2 or 1.3 criteria.
	A2	Provide aeration sheets along accessible surfaces (foundations and curbs)
Urban 5	Constraint Level 16 - Graded BUT Not Compacted / 70% - 90% Impervious	
	S3	Dig the planting hole 6 feet larger in diameter than the root ball diameter. Excavate the remaining area of soil in planters and lawn to a depth of 8 inches. Till the resulting subgrade with the first 4-6 inches of planting soil mix.
	D3.1	Trees within new paving, provide subsurface drain lines to remove water from the site which connect from tree to tree.
	D3.2	Trees within existing paving, perform a perc test. If the perc of existing soil is 1 inch/hour or greater, install drainage sump with subsurface drain line in ring around tree. If perc is less than 1 inch/hour, do not plant trees unless drainage is improved.
	A2	Provide aeration sheets along accessible surfaces (foundations and curbs)

Mitigation by Degree of Urbanization - Unconstrained to Highly Constrained

Urban 6

Constraint Level 17 - Not Graded BUT Compacted / 90% or More Impervious

- S3** Dig the planting hole 6 feet larger in diameter than the root ball diameter. Excavate the remaining area of soil in planters and lawn to a depth of 8 inches. Till the resulting subgrade with the first 4-6 inches of planting soil mix.
- D3.1** Trees within new paving, provide subsurface drain lines to remove water from the site which connect from tree to tree.
- D3.2** Trees within existing paving, perform a perc test. If the perc of existing soil is 1 inch/hour or greater, install drainage sump with subsurface drain line in ring around tree.
If perc is less than 1 inch/hour, do not plant trees unless drainage is improved.
- A3.1** Within existing paving, provide aeration sheets within the planting area.
- A3.2** With new paving, provide aeration sheets within the planting areas and under paved areas. Install coarse gravel subbase under all paved areas. Install open joint unit pavers where applicable / specified to achieve minimum pervious planting area.

Urban 7

Constraint Level 18 - Graded and Compacted / 70% - 90% Impervious

- S4** Excavate all areas available for planting and lawn to a depth of 2.5 feet. Till the resulting subgrade with the first 4-6 inches of planting soil mix.
Calculate the quantity of planting soil mix to determine that the volume of soil per tree being provided is sufficient to grow the tree specified.
Modify the design to allow for adequate soil volume.
- D3.1** Trees within new paving, provide subsurface drain lines to remove water from the site which connect from tree to tree.
- D3.2** Trees within existing paving, perform a perc test. If the perc of existing soil is 1 inch/hour or greater, install drainage sump with subsurface drain line in ring around tree.
If perc is less than 1 inch/hour, do not plant trees unless drainage is improved.
- A3.1** Within existing paving, provide aeration sheets within the planting area.
- A3.2** With new paving, provide aeration sheets within the planting areas and under paved areas. Install coarse gravel subbase under all paved areas. Install open joint unit pavers where applicable / specified to achieve minimum pervious planting area.

Mitigation by Degree of Urbanization - Unconstrained to Highly Constrained

Urban 8	Constraint Level 19 - Graded BUT Not Compacted / 90% or More Impervious	
	Constraint Level 20 - Graded and Compacted / 90% or More Impervious	
	S5	Perform the requirements of Step S4. Design additional subsurface soil volumes below the adjacent paving as required to provide all adequate soil volume. Interconnect these soil volumes when possible.
	D3.1	Trees within new paving, provide subsurface drain lines to remove water from the site which connect from tree to tree.
	D3.2	Trees within existing paving, perform a perc test. If the perc of existing soil is 1 inch/hour or greater, install drainage sump with subsurface drain line in ring around tree. If perc is less than 1 inch/hour, do not plant trees unless drainage is improved.
A4	Install watering tubes within the gravel subbase plus meet A3 requirements.	

Source: *Bringing Order to the Technical Dysfunction within the Urban Forest, J. Urban, ISA Annual Conference 1991*

Graded
Compacted

topsoil removed or disturbed and relocated on site
compressed to a bulk density that prohibits root growth (worst case should be assumed)

Surface Mitigation by Degree of Urbanization - Unconstrained to Highly Constrained

		Constraint Level 1 - Not Graded and Not Compacted / 15% or Less Impervious			
		Constraint Level 2 - Not Graded BUT Compacted / 15% or Less Impervious			
		Constraint Level 3 - Not Graded and Not Compacted / 15% - 50% Impervious		ID Inspection Schedule	
		Constraint Level 4 - Graded and Compacted / 15% or Less Impervious			
Unconstrained	<i>assigned mitigation</i>	S1	Dig the planting hole 24 inches larger in diameter than the root ball diameter. Backfill with unamended soil excavated from the hole.		Provide Cross Section detail.
		D1.1	Percolation of existing soil 2 inches / hour or greater. Positive surface drainage, min. 2%.		Require Perc Test. Prepare spec.
		D1.2	Percolation of existing soil 1- 2 inches / hour or greater. Increase positive surface drainage in planting areas to 10% away from the tree (mounding)		
		D1.3	Percolation of existing soil less than 1 inch/ hour or greater. Mound planting soil in area at least 20% so rootball is entirely above existing grade OR add subsurface drain lines around tree and loosen soil to a depth of 12 inches.		
		A1	Provide for periodic aeration and/or mulching of the ground within the dripline of the tree.		Provide written spec
		Constraint Level 5 - Not Graded BUT Compacted / 15% - 50% Impervious			
		Constraint Level 6 - Not Graded and not Compacted / 50% - 70% Impervious		ID Inspection Schedule	
Urban 1	<i>assigned mitigation</i>	S2	Dig the planting hole 6 feet larger in diameter than the root ball diameter. Backfill with unamended soil excavated from the hole.		Provide Cross Section detail.
		D1.1	Percolation of existing soil 2 inches / hour or greater. Positive surface drainage, min. 2%.		Require Perc Test. Prepare spec.
		D1.2	Percolation of existing soil 1- 2 inches / hour or greater. Increase positive surface drainage in planting areas to 10% away from the tree (mounding)		
		D1.3	Percolation of existing soil less than 1 inch/ hour or greater. Mound planting soil in area at least 20% so rootball is entirely above existing grade OR add subsurface drain lines around tree and loosen soil to a depth of 12 inches.		Detail for subsurface drain lines.
		A1	Provide for periodic aeration and/or mulching of the ground within the dripline of the tree.		Provide spec (interval and method)
		Constraint Level 7 - Graded and Compacted / 15% or Less Impervious			
		Constraint Level 8 - Graded BUT Not Compacted / 15% - 50% Impervious			
		Constraint Level 9 - Not Graded BUT Compacted / 50% - 70% Impervious		ID Inspection Schedule	
		Constraint Level 10 - Not Graded and Not Compacted / 70% - 90% Impervious			
Urban 2	<i>assigned mitigation</i>	S2	Dig the planting hole 6 feet larger in diameter than the root ball diameter. Backfill with unamended soil excavated from the hole.		Provide Cross Section detail.
		D2	Unpredictable percolation. Move existing water away from the site by providing subsurface drain lines within planting area and/ OR provide a drain sump pit at each tree. Perform perc test at each tree; apply D1.1, 1.2 or 1.3 criteria.		
		A2	Provide aeration sheets along accessible surfaces (foundations and curbs)		Provide specs and detail.

Surface Mitigation by Degree of Urbanization - Unconstrained to Highly Constrained

		Constraint Level 11 - Graded and Compacted / 15% - 50% Impervious		Constraint Level 12- Graded BUT Not Compacted / 50% - 70% Impervious		Constraint Level 13 - Not Graded BUT Compacted / 70% - 90% Impervious		Constraint Level 14- Not Graded and Not Compacted / 90% or More Impervious		ID Inspection Schedule		
Urban 3	<i>assigned mitigation</i>	S3	Dig the planting hole 6 feet larger in diameter than the root ball diameter. Excavate the remaining area of soil in planters and lawn to a depth of 8 inches. Till the resulting subgrade with the first 4-6 inches of planting soil mix.								Provide Cross Section detail. Provide written spec.	
		D2	Unpredictable percolation. Move existing water away from the site by providing subsurface drain lines within planting area and/ OR provide a drain sump pit at each tree. Perform perc test at each tree; apply D1.1, 1.2 or 1.3 criteria.									Always situation; provide detail for subsurface drain lines.
		A2	Provide aeration sheets along accessible surfaces (foundations and curbs)									Provide detail and written spec.
		Constraint Level 15 - Graded and Compacted / 50% - 70% Impervious		Constraint Level 15 - Graded and Compacted / 50% - 70% Impervious		Constraint Level 15 - Graded and Compacted / 50% - 70% Impervious		Constraint Level 15 - Graded and Compacted / 50% - 70% Impervious		ID Inspection Schedule		
Urban 4	<i>assigned mitigation</i>	S4	Excavate all areas available for planting and lawn to a depth of 2.5 feet. Till the resulting subgrade with the first 4-6 inches of planting soil mix. Calculate the quantity of planting soil mix to determine that the volume of soil per tree being provided is sufficient to grow the tree specified. Modify the design to allow for adequate soil volume.								Establish volume standards for small, med and large trees.	
		D2	Unpredictable percolation. Move existing water away from the site by providing subsurface drain lines within planting area and/ OR provide a drain sump pit at each tree. Perform perc test at each tree; apply D1.1, 1.2 or 1.3 criteria.								Alt, provide detail for mitigation (silva cell/ structural soil.	
		A2	Provide aeration sheets along accessible surfaces (foundations and curbs)									Provide detail and written spec.
		Constraint Level 16 - Graded BUT Not Compacted / 70% - 90% Impervious		Constraint Level 16 - Graded BUT Not Compacted / 70% - 90% Impervious		Constraint Level 16 - Graded BUT Not Compacted / 70% - 90% Impervious		Constraint Level 16 - Graded BUT Not Compacted / 70% - 90% Impervious		ID Inspection Schedule		
Urban 5	<i>assigned mitigation</i>	S3	Dig the planting hole 6 feet larger in diameter than the root ball diameter. Excavate the remaining area of soil in planters and lawn to a depth of 8 inches. Till the resulting subgrade with the first 4-6 inches of planting soil mix.								Provide Cross Section detail. Provide written spec.	
		D3.1	Trees within new paving, provide subsurface drain lines to remove water from the site which connect from tree to tree.								Provide detail and written spec.	
		D3.2	Trees within existing paving, perform a perc test. If the perc of existing soil is 1 inch/hour or greater, install drainage sump with subsurface drain line in ring around tree. If perc is less than 1 inch/hour, do not plant trees unless drainage is improved.								Require perc test. Provide detail for sump and drain line.	
		A2	Provide aeration sheets along accessible surfaces (foundations and curbs)									Provide detail and written spec.

Surface Mitigation by Degree of Urbanization - Unconstrained to Highly Constrained

		<i>ID Inspection Schedule</i>		
Constraint Level 17 - Not Graded BUT Compacted / 90% or More Impervious				
Urban 6	<i>assigned mitigation</i>	<p>S3 Dig the planting hole 6 feet larger in diameter than the root ball diameter. Excavate the remaining area of soil in planters and lawn to a depth of 8 inches. Till the resulting subgrade with the first 4-6 inches of planting soil mix.</p> <p>D3.1 Trees within new paving, provide subsurface drain lines to remove water from the site which connect from tree to tree.</p> <p>D3.2 Trees within existing paving, perform a perc test. If the perc of existing soil is 1 inch/hour or greater, install drainage sump with subsurface drain line in ring around tree. <i>If perc is less than 1 inch/hour, do not plant trees unless drainage is improved.</i></p> <p>A3.1 Within existing paving, provide aeration sheets within the planting area.</p> <p>A3.2 With new paving, provide aeration sheets within the planting areas and under paved areas. Install coarse gravel subbase under all paved areas. <i>Install open joint unit pavers were applicable / specified to achieve minimum pervious planting area.</i></p>	<p>Provide Cross Section detail. Provide written spec.</p> <p>Provide detail and written spec.</p> <p>Require perc test. Provide detail for sump and drain line.</p> <p>Provide detail and written spec.</p> <p>Provide detail and written spec.</p> <p>Provide detail and written spec.</p> <p>Alt, provide detail for mitigation (silva cell/ structural soil).</p>	
	Constraint Level 18 - Graded and Compacted / 70% - 90% Impervious			
	Urban 7	<i>assigned mitigation</i>	<p>S4 Excavate all areas available for planting and lawn to a depth of 2.5 feet. Till the resulting subgrade with the first 4-6 inches of planting soil mix. Calculate the quantity of planting soil mix to determine that the volume of soil per tree being provided is sufficient to grow the tree specified. Modify the design to allow for adequate soil volume.</p> <p>D3.1 Trees within new paving, provide subsurface drain lines to remove water from the site which connect from tree to tree.</p> <p>D3.2 Trees within existing paving, perform a perc test. If the perc of existing soil is 1 inch/hour or greater, install drainage sump with subsurface drain line in ring around tree. <i>If perc is less than 1 inch/hour, do not plant trees unless drainage is improved.</i></p> <p>A3.1 Within existing paving, provide aeration sheets within the planting area.</p> <p>A3.2 With new paving, provide aeration sheets within the planting areas and under paved areas. Install coarse gravel subbase under all paved areas. <i>Install open joint unit pavers were applicable / specified to achieve minimum pervious planting area.</i></p>	<p>Provide Cross Section detail. Provide written spec.</p> <p>Provide detail and written spec.</p> <p>Require perc test. Provide detail for sump and drain line.</p> <p>Provide detail and written spec.</p> <p>Provide detail and written spec.</p> <p>Provide detail and written spec.</p> <p>Alt, provide detail for mitigation (silva cell/ structural soil).</p>
		Constraint Level 19 - Graded BUT Not Compacted / 90% or More Impervious		
		Constraint Level 20 - Graded and Compacted / 90% or More Impervious		
Urban 8		<i>assigned mitigation</i>	<p>S5 Perform the requirements of Step S4. Design additional subsurface soil volumes below the adjacent paving as required to provide all adequate soil volume. Interconnect these soil volumes when possible.</p> <p>D3.1 Trees within new paving, provide subsurface drain lines to remove water from the site which connect from tree to tree.</p> <p>D3.2 Trees within existing paving, perform a perc test. If the perc of existing soil is 1 inch/hour or greater, install drainage sump with subsurface drain line in ring around tree. <i>If perc is less than 1 inch/hour, do not plant trees unless drainage is improved.</i></p> <p>A4 Install watering tubes within the gravel subbase plus meet A3 requirements.</p>	<p>Provide Cross Section detail. Provide written spec.</p> <p>Provide detail for mitigation (silva cell/ structural soil).</p> <p>Provide detail and written spec.</p> <p>Require perc test. Provide detail for sump and drain line.</p> <p>Provide detail and written spec.</p>

Source: Bringing Order to the Technical Dysfunction within the Urban Forest, J. Urban, ISA Annual Conference 1991

** When is soil amendment/ supplement/ replacement req'd?*

SMALL TREE - 300 CF

- ▨ SILVACELL
- OPEN SPACE / CUT OUT "OSCU"

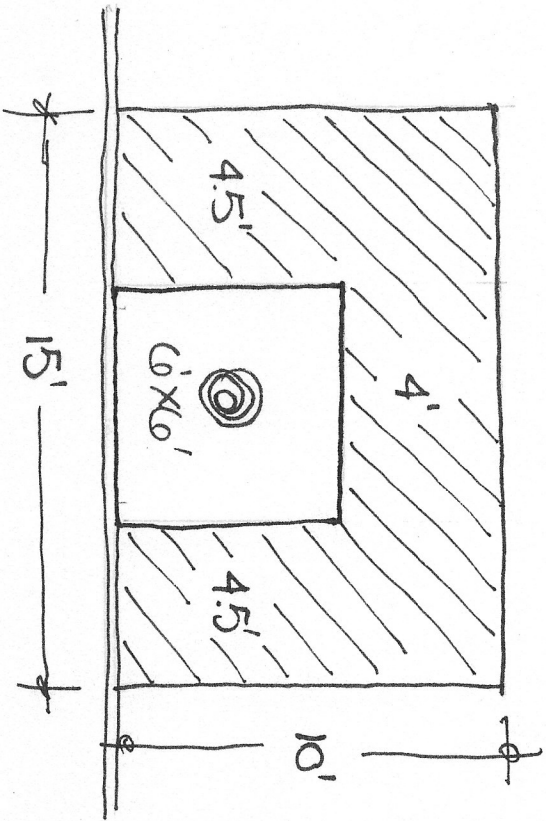

e 2' DEPTH = 150 SF
15' x 10'

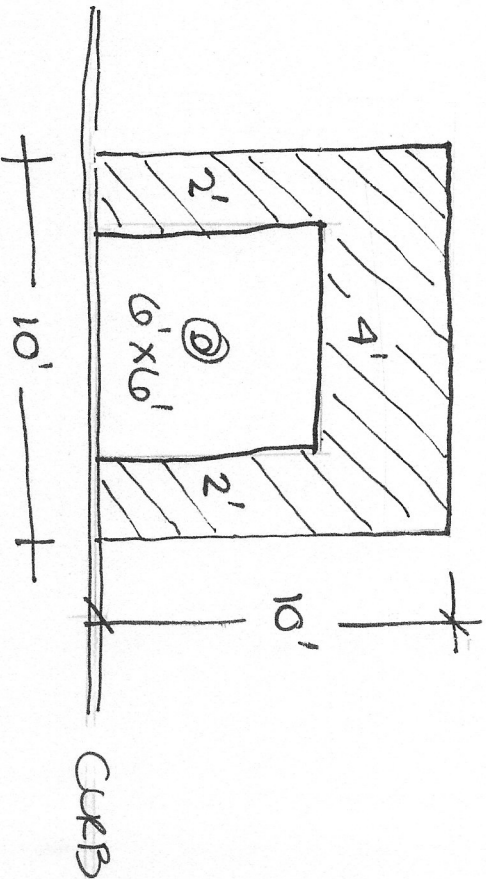

e 3' DEPTH = 100 SF
10' x 10'

MEDIUM TREE - 1200 CF

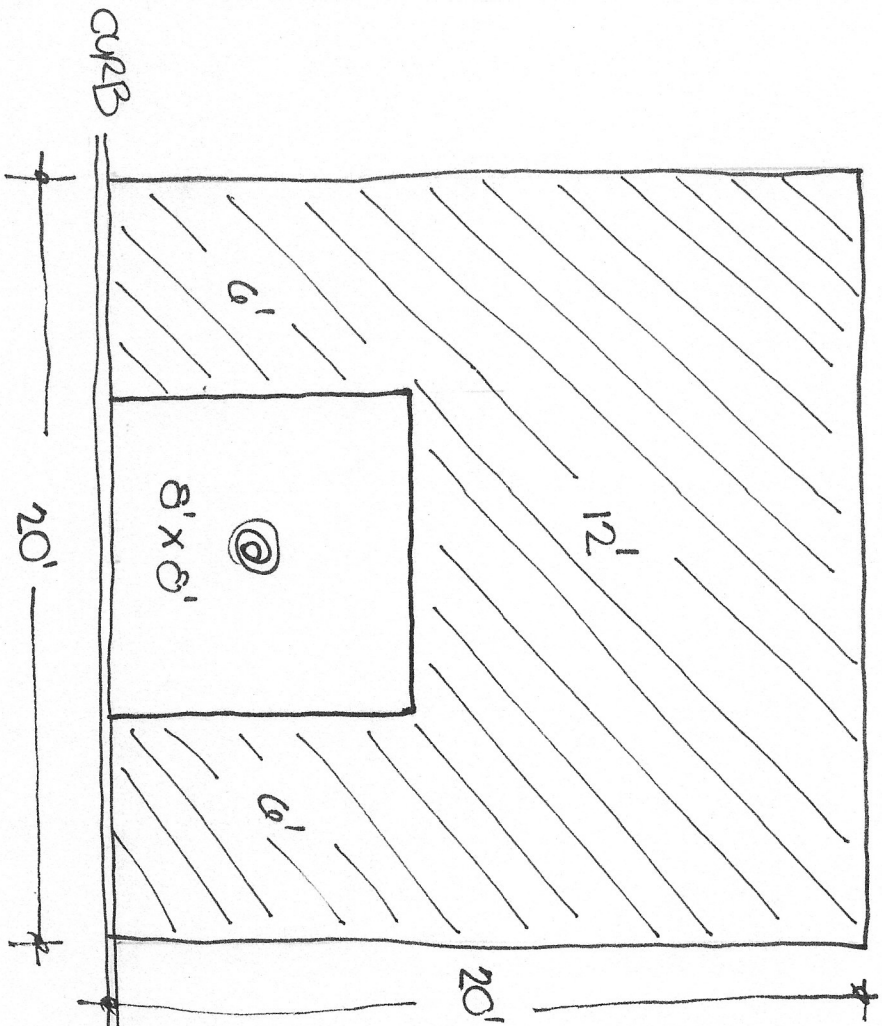

• 3' DEPTH = 400 SF
20' x 20'

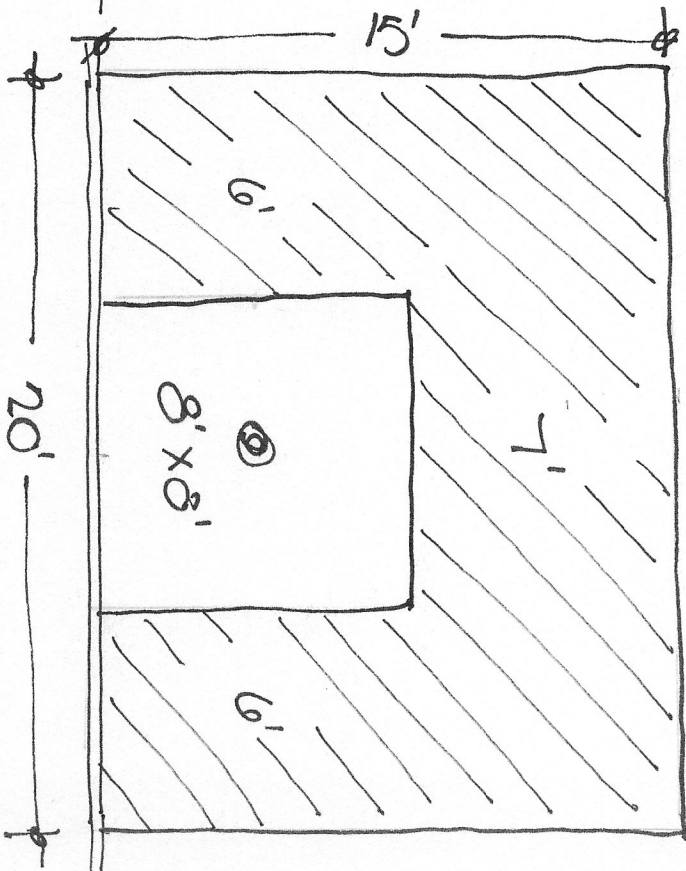

• 4' DEPTH = 300 SF
20' x 15'

LARGE TREE = 1800 CF

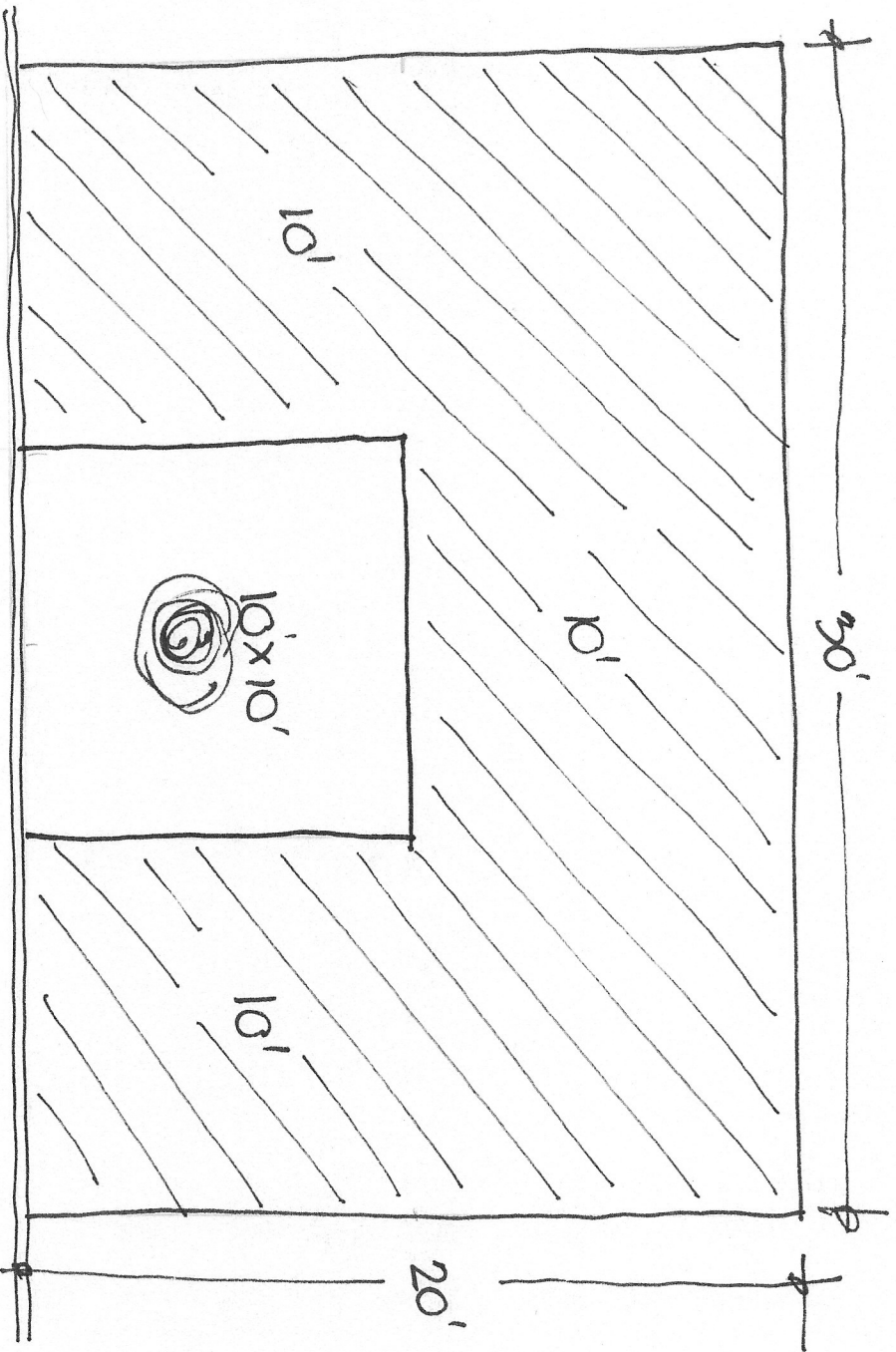

C 2' DEPTH = 6000 SF

20' x 30'

LARGE TREE = 1800 SF

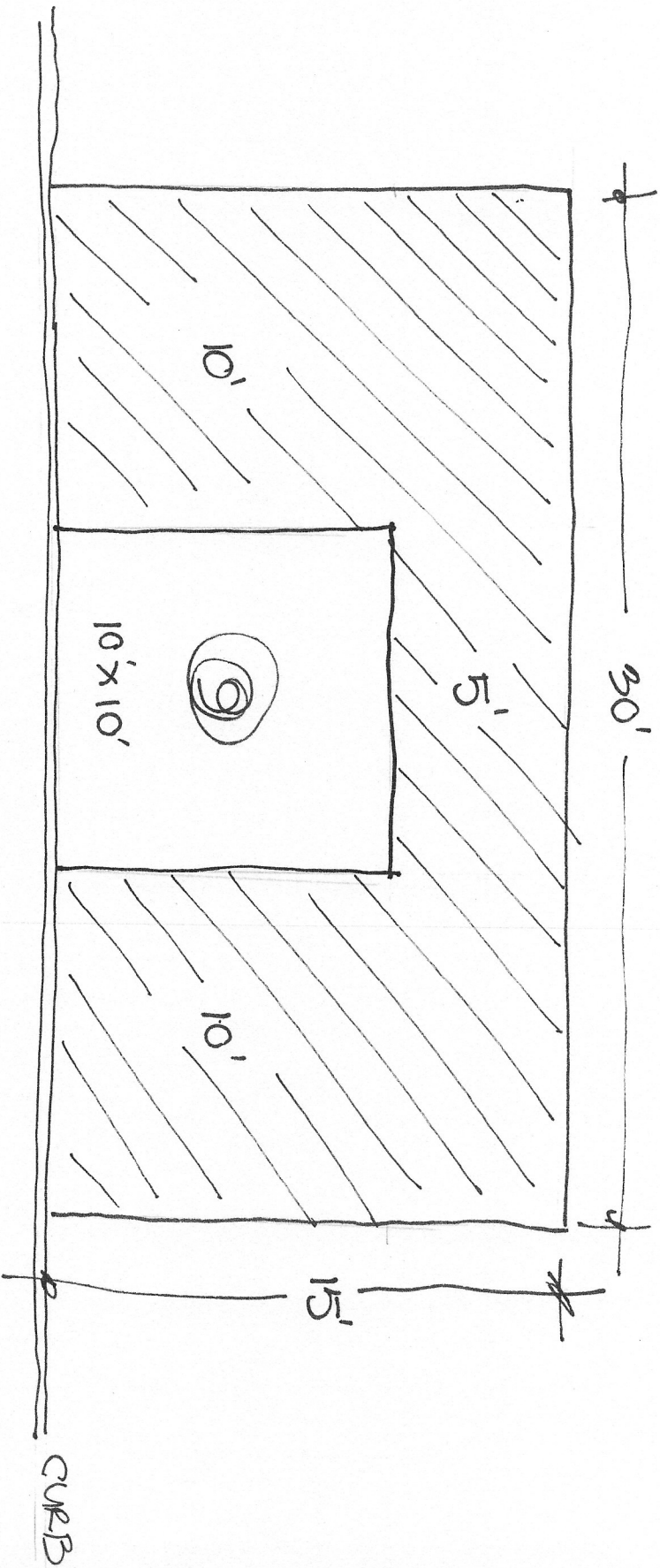

@ 4' DEPTH = 450 SF
15' x 30'

Task Force on Urban Tree Planting Best Practices

Minutes

Tuesday February 19th, 2025, - 10:00am

Via Zoom Platform & In Person

[Recording of Meeting can be obtained by sending request to Joe Rainey JRainey@coj.net]

Commissioners:

Nina Sickler, Director of Public Works
Susan Fraser, Chair (Council Appointee; 2022-0063-A)
William Burke (Mayor Appointee; 2023-0695-A)

Non-Member attendees:

Jeff Lucovsky, PDDS
Jonathan Johnston, Parks
Guy Parola, DIA
Nancy Powell, Scenic Jax
Lisa Grubba, Greenscape
Joe Anderson JEA
Valerie Feinberg, Fuse Fellow, UFMP

Advisors:

Jonathan Colburn - Urban Forestry Manager
Justin Gearhart - City Arborist
Shannon MacGillis - Office of General Counsel

Staff: Joe Rainey - Executive Assistant Mowing and Landscape

1. Call to Order

Conducted by Chair

2. Roll Call and Verification of Quorum

Conducted by Chair

Commissioners present:

Susan Fraser - Chair
Nina Sickler
William Burke

Quorum present (4, in person): Yes

3. Call for Public Speakers (online & card): Speakers request to defer to respond within context of action items.

Action Items:

4. Submittal of speaker cards

5. Prior Meeting Minutes.

Issue: The minutes from January 27, 2025, APPROVED

Motion: Approve, as presented.

Moved by: Nina Sickler

Second: William Burke

Vote: November minutes approved, unanimous.

Presentations:

6. Existing Standards Review presentations

a. **ANSI A300 - Susan Fraser** (see Item 6a, pgs. 4-6 of Agenda) Overview of tree care standards based on ANSI recommendations provided in support document.

b. **JEA Underground Utilities - Joe Anderson** (see Item 6b, pgs. 7-8 of Agenda) Discussion of installation and development of tree projects in urban locals. Focus on the complications and dangers utilities may contain when planning and maintaining.

c. **Minimum Planting Area Detail - Susan Fraser** (see Item 6c, pgs. 8-9 of supplement) Documents provided day of meeting to be included in supplemental documents. Brief detail of documents and relation to Urban article.

d. **Silva Cell Details - JTA Busway on Park Street - Anna Walling** (see Item 6d, pgs. 10-24 of Agenda) Overview of drafts and documents for presentation on structural soils, silva cells and their applications in relation to tree planting projects. Discussion was included in presentation.

e. **Vertical Constraints - Jonathan Colburn**

Issue: (see Item 6e, pgs. 25-27 of Agenda)

Overview with discussion of vertical constraints related to tree selection, location, obstructions, limitations and maintenance. Details found on support documents.

f. Existing Tree Fund Projects' Irrigation Approach - Jonathan Colburn (see Item 6f, pgs. 28-29 of Agenda)

Review of current contracts for tree planting regarding tree watering. Types of irrigation, applications and follow-through after warranty ends.

Discussion: Fraser: Question about volume vs frequency, to be found in further contract documents not provided.

7. Downtown Investment Authority

a. Design Guidebook - Guy Parola

DIA has previously contracted consultants to study what the taskforce is exploring. The design guidebook describes the aesthetic applications of trees and plant installs related to how they work with surrounding banners and other design aspects of downtown. DIA is looking to gain insight into how to merge the aesthetics with best practice plant selection, install and maintenance technics.

b. Examples of Utility Conflicts Downtown - Guy Parola

DIA is finding unmarked or unmapped utilities when implementing designs, they are seeking standards or options that will help alleviate utility constraints or resolve when unexpected utilities are found on ROWs. **Fraser:** How about Raised Planters?

8. The Good, Bad and Ugly

9. Development of Constrained Planting Environment Standards

a. Overview "Bringing Order to the Technical Dysfunction within the Urban

Forest", Journal of Arboriculture Volume 18, issue 2, March 1992

Read through of article and their relation to and application to City of Jacksonville tree planting solutions.

b. Application of Approach and Matrix to Jacksonville

i. Matrix

ii. Mitigation by Degree of Urbanization

iii. Outline of Needed Specifications and Details

iv. Application Requirements Level 2 and 3 Check

Fraser: How-to for use of matrix with detailed examples.

Overview of specific problems relevant to current Jacksonville processes.

10. Expand Approved Tree Planting List to Include:

- i. Planting Zone
- ii. Mature Height and Spread
- iii. Root Characteristics (invasive?)
- iv. Suitability as a street tree adjacent to pedestrians
- v. Suitability as street tree without pedestrian adjacency
- vi. Maintenance Score
- vii. Wind Resistance
- viii. Water requirements minimum and Optimum
- ix. soil volume required
- x. Lifespan
- xi. Crown shape

11. Meeting Dates for March - May 2025

March 20th 11am -2pm

April 17th 11am -2pm

May 14th 11am -2pm

ADJOURNMENT

END OF MEETING 3:32PM

APPROVED